

THE PROBLEM OF STABILITY OF MINIMAL SUBMANIFOLDS IN RIEMANNIAN AND PSEUDO-RIEMANNIAN SPACES

YURIJ AMINOV

*Institute of Mathematics, University of Bialystok
2 Akademicka Street, 15-267 Bialystok, Poland*

Abstract. Here we present a review of the results in the theory of the submanifolds related to the notion of area and mean curvature vector. It is shown that if r is the radius vector of the submanifold F^n in the Euclidean space E^{n+p} , $\rho = \frac{1}{2}r^2$ and H is the corresponding mean curvature vector, then the Laplace-Beltrami operator satisfies $\nabla_2\rho = n(1 + rH)$ and therefore in the case of a minimal submanifold one has $\nabla_2\rho = n$. When $n = 2$ it is proven that if we have a complete submanifold $F^n \subset E^N$ with $|H| \leq H_0 = \text{const}$ and Ricci curvature $\text{Ric}(\tau) \geq -a^2 = \text{const}$ in a ball of radius R then $R \geq \frac{n}{2\sqrt{n-2}a+H_0n}$. The Chern's problem of existence of a complete and unbounded minimal surface is considered in some depth. Next we consider the conditions of stability of the minimal submanifolds. For submanifolds in Riemannian spaces the problem of stability is connected with the Hopf problem about the existence of metrics with positive curvatures on $S^2 \times S^2$. It is shown that a two-dimensional minimal surface F^2 homeomorphic to the sphere S^2 in a oriented simply-connected manifold M^n with a sectional curvature $\frac{1}{4} < K_\sigma \leq 1$ is non-stable. Pogorelov's result about minimal surfaces in $S^2 \times S^n$, $n > 2$ is outlined as well. Finally, an expression is derived for the Riemannian tensor of a submanifold defined implicitly by a system of equations in the Euclidean space and a remarkably simple formula is found for the Gaussian curvature of $F^2 \subset E^4$.

1. The Vector of Mean Curvature of a Submanifold in the Riemannian Space

Let us consider some regular submanifold $F^n \subset E^{n+p}$ in the Euclidean space.

Definition. We call F^n a minimal submanifold if for every point $x_0 \in F^n$ there exists some neighborhood $U(x_0)$ such that for any variation of $U(x_0)$ with fixed boundary of $U(x_0)$ the n -volume of $U(x_0)$ does not decrease.

We can reformulate this definition in geometrical terms. If $ds^2 = g_{ij} du^i du^j$ is the metric of F^n and $g = |g_{ij}|$, then the n -dimensional volume V can be represented as the integral

$$V = \int \sqrt{g} du^1 \cdots du^n .$$

Let us now consider a special variation of F^n . In a small neighborhood of x_0 we can construct p normal fields ξ_1, \dots, ξ_p which consist of unit orthogonal to each other vectors.

Let $r = r(u^1, \dots, u^n)$ is the position vector in F^n and $\bar{r} = \bar{r}(u^1, \dots, u^n, \varepsilon)$ is its variation where ε is a small parameter.

We take the variation in the following form

$$\bar{r} = r + \varepsilon w \xi_\alpha ,$$

where w is some regular function of a point $x \in F^n$ with the condition $w|_{\partial U(x_0)} = 0$, and α is a fixed number. We have

$$\bar{r}_{u^i} = r_{u^i} + \varepsilon w \xi_{\alpha u^i} + \varepsilon w_{u^i} \xi_\alpha .$$

By using the Weingarten decomposition of the derivatives $\xi_{\alpha u^i}$ we have

$$\bar{r}_{u^i} = r_{u^i} + \varepsilon w (-L_{il}^\alpha g^{lk} r_{u^k} + \mu_{\alpha\rho|i} \xi_\rho) + \varepsilon w_{u^i} \xi_\alpha ,$$

where $\mu_{\alpha\rho|i}$ are the torsion coefficients.

Therefore the metric tensor \bar{g}_{ij} of \bar{F}^n has the form

$$\bar{g}_{ij} = (\bar{r}_{u^i} \bar{r}_{u^j}) = g_{ij} - 2\varepsilon w L_{ij}^\alpha + \cdots ,$$

where L_{ij}^α are the coefficients of the second quadratic form corresponding to the normal fields ξ_α , and dots denote the members with ε^2 . If we put

$$g_i = \begin{pmatrix} g_{1i} \\ \vdots \\ g_{ni} \end{pmatrix}, \quad L_i^\alpha = \begin{pmatrix} L_{1i}^\alpha \\ \vdots \\ L_{ni}^\alpha \end{pmatrix}$$

then

$$\begin{aligned}\bar{g} &= [g_1 - 2\varepsilon w L_1^\alpha, g_2 - 2\varepsilon w L_2^\alpha, \dots] \\ &= [g_1, \dots, g_n] - 2\varepsilon w \sum_{k=1}^n [g_1, \dots, L_k^\alpha, \dots, g_n] + \dots\end{aligned}$$

The algebraic minor of L_{ij}^α is $g g^{ij}$. Hence

$$\sqrt{\bar{g}} = \bar{g}(1 - \varepsilon w L_{ij}^\alpha g^{ij}) + \dots$$

The first variation of the volume for $\varepsilon = 0$ has the form

$$\left. \frac{dV}{d\varepsilon} \right|_{\varepsilon=0} = - \int w L_{ij}^\alpha g^{ij} dV,$$

where dV is the volume element of F^n . In this way we obtain that

$$L_{ij}^\alpha g^{ij} = 0.$$

Here we can take $\alpha = 1, \dots, p$.

Let us now introduce the vector which belongs to the normal space of F^n

$$H = \frac{1}{n} \sum_{\alpha=1}^p L_{ij}^\alpha g^{ij} \xi_\alpha.$$

We call H the vector of **mean curvature** of the submanifold F^n .

Theorem 1.1. *The vector of mean curvature for minimal submanifold is equal to zero, i. e.*

$$H = 0.$$

We can introduce also the vector H for submanifolds in the Riemannian space also. A similar theorem is also true.

Let ϕ is a regular function on F^n and ϕ_{ij} are its covariant derivatives with respect to g_{ij} . The Laplace–Beltrami operator has the form

$$\nabla_2 \phi = \phi_{ij} g^{ij}.$$

Now we consider every component of r as a function on F^n . By using the Gauss decomposition we have

$$\nabla_2 r = r_{ij} g^{ij} = L_{ij}^\alpha g^{ij} \xi_\sigma = 0.$$

Hence, all components of the position vector r of any minimal submanifold in Euclidean space satisfy the Laplace–Beltrami equation.

This circumstance makes the theory of minimal submanifolds close to the theory of analytic functions.

Let us consider now the function

$$\rho = \frac{1}{2}r^2.$$

We have $\rho_i = rr_i$ and

$$\rho_{,ij} = g_{ij} + rr_{,ij} = g_{ij} + r\xi_\alpha L_{ij}^\alpha.$$

Hence, for an arbitrary submanifold $F^n \subset E^{n+p}$ we have

$$\nabla_2 \rho = n(1 + rH).$$

If F^n is minimal, then

$$\nabla_2 \rho = n.$$

We will use this simple equation to prove the following property: *a minimal submanifold in Euclidean space can not be closed.*

Indeed, if F^n is a closed and regular, then there exists a point P_0 with maximal value of the function ρ . At this point all $\rho_i = 0$ and the ordinary derivatives satisfy $\frac{\partial^2 \rho}{\partial u^i \partial u^i} \leq 0$. But at that point

$$\rho_{,ii} = \frac{\partial^2 \rho}{\partial u^i \partial u^i} - f_{ii}^k \rho_k = \frac{\partial^2 \rho}{\partial u^i \partial u^i}.$$

Therefore $\nabla_2 \rho \leq 0$, and that contradicts with the equation $\nabla_2 \rho = n$.

Chern [1] suggested that perhaps a complete minimal submanifold F^n in Euclidean space E^{n+p} is unbounded.

For a minimal surface $F^2 \subset E^m$ I have proved this hypothesis under the condition that the Gauss curvature of F^2 is bounded from below [2]. In the same article I have proved also the following theorem:

Theorem 1.2. *Let the complete surface $F^2 \subset E^N$ with $|H| \leq H_0 = \text{const}$ and with Gauss curvature bounded from bellow lies in a ball with radius R . Then*

$$R \geq \frac{1}{H_0}. \quad (1.1)$$

Corollary. *A complete minimal surface $F^2 \subset E^N$ with Gauss curvature limited from bellow is unbounded in the space E^N .*

For $n > 2$ I have obtained an estimate which depends on H_0 and the lower boundary of the Ricci curvature $\text{Ric}(\tau)$ for the tangent vector τ .

Theorem 1.3. *Let the complete Riemannian submanifold $F^n \subset E^N$ with $|H| \leq H_0$ and $\text{Ric}(\tau) \geq -a^2 = \text{const}$ lies in a ball with radius R . Then*

$$R \geq \frac{n}{2\sqrt{n-2a+H_0n}}. \quad (1.2)$$

To demonstrate the idea of the proofs we consider the case $n = 2$.

Let F^n lies in a ball with radius R . Let the origin of the coordinate system lies at the center of the ball. If F^n is closed, then there exists a point with maximal value of ρ and at that point

$$0 \geq \nabla_2 \rho \geq n(1 - Hr) \geq n(1 - H_0R).$$

So for closed F^n the estimates (1) and (2) are true.

Now consider non-closed but a complete surface $F^2 \subset E^N$. Let $1 - H_0R = m_0 > 0$. We introduce a new metric

$$d\sigma^2 = e^{-2\mu\rho} ds^2,$$

where ds^2 is the metric on F^2 and μ is a positive number which we shall choose later. If K is the Gaussian curvature of the metric ds^2 , then the Gaussian curvature of $d\sigma^2$ has the expression

$$K_\sigma = e^{-2\mu\rho}(K + \mu\nabla_2\rho).$$

By the assumption of the previous theorem there exists some number a , such that $K \geq -a^2$ on the whole F^2 . We have $\nabla_2\rho \geq m_0 > 0$. So, if μ is enough large ($2m_0\mu > a^2$), then the curvature K_σ is positive, and we will have the estimate

$$K_\sigma \geq -a^2 + 2m_0\mu > 0. \quad (1.3)$$

Let D is a region on the surface F^2 with an inner radius r and let O is a point in D which distance from O to the boundary of D is equal to r . Let f is the shortest curve with respect to the metric $d\sigma^2$ going from O to the boundary of D . We denote its length by L_σ . Then we have

$$L_\sigma \geq \int_\Gamma d\sigma = \int_\Gamma e^{-\mu\rho} ds \geq e^{-\mu R^2/2} r.$$

Because the curvature K_σ is bounded by a positive number, we can indicate the estimate for this length

$$L_\sigma \leq \frac{\pi}{\sqrt{2m_0\mu - a^2}}. \quad (1.4)$$

By using estimates (1.3) and (1.4) we obtain

$$\ln \frac{r\sqrt{2m_0\mu - a^2}}{\pi} \leq \frac{\mu R^2}{2}.$$

Let us take μ such that the expression under the sign of \ln is greater than 1 for all numbers r . For example, if $a \neq 0$ then we can put

$$\mu = \frac{a^2}{m_0} + \frac{\pi}{2m_0r^2}.$$

We have

$$m_0 \ln(1 + (ar/\pi)^2) < (a^2 + \frac{\pi^2}{2r^2})R^2.$$

Let us introduce the following function which depends on r

$$\psi = (a^2 + \frac{\pi^2}{2r^2})^{-1} \ln(1 + (\frac{ar}{\pi})^2).$$

Then

$$R^2 \geq m_0\psi.$$

Now we have the inequality

$$R^2 > (1 - H_0R)\psi,$$

and then

$$R \geq \frac{\psi}{\sqrt{H_0^2\psi^2 + 4\psi}}.$$

Because for $r \rightarrow \infty$ the function $\psi \rightarrow \infty$ as well, we obtain

$$R \geq \frac{1}{H_0}.$$

All those means that the estimate (1.1) is proved.

For n -dimensional submanifold with $n > 2$ and with bounded from bellow sectional curvature the estimate (1.1) was obtained in the work by Hasanis and Koutroufiotis in [3]. They have used the strong and beautiful work by Omori [4]. There he considered the behaviour of a smooth function f on the complete Riemannian space M and proved the following theorem

Theorem 1.4. *Let M is a connected and complete Riemannian manifold whose sectional curvature $K(X, Y)$ has a lower bound, i. e. $K(X, Y) \geq -K_0$. If a smooth function f on M has an upper bound, then for any $\varepsilon > 0$, there exists a point $p \in M$ such that $\|\text{grad } f(p)\| < \varepsilon$ and $m(p) = \max[X^i X^j \nabla_i \nabla_j f(p); \|X\| = 1] < \varepsilon$.*

By its definition $m(p)$ is maximal among all second derivatives f_{ss} along all geodesic curves of M with respect to the arc length s .

The condition on the curvature K is important. Take on E^2 the metric $dr^2 + g(r) d\theta^2$ where the function $g(r)$ satisfies: (a) $g(r)$ is smooth and $g(r) = r$ for

$0 \leq r < \frac{1}{2}$; (b) $g(r)$ is a solution of $\frac{g'(r)}{g(r)} = \frac{2c}{f'(r)}$. Let $f(r, \theta) = \frac{r^2}{1+r^2}$. Since

$$dx^i dx^j \nabla_i \nabla_j f = f''(r) dr^2 + \frac{1}{2} f'(r) g'(r) d\theta^2,$$

so $m(p)$ is bounded below from 0. Omori gave also some applications of the above cited theorem to submanifolds, but these applications were not connected with the function ρ .

Let us now apply Theorem 1.3 to the function ρ . If ρ is bounded from below, then for any $\epsilon > 0$ there exists a point with $\nabla_2 \rho \leq \epsilon$ that contradicts equation $\nabla_2 \rho = n$. The theorem from [3] is proved.

We remark that the estimate (2), which contains the Ricci curvature $\text{Ric}(\tau)$ now is near the best.

In connection with Chern hypothesis let us note the work of Jorge and Xavier [5] in which they have answered the Calabi question: does there exist a complete minimal surface in E^3 entirely contained in half-space which is different from the plane? They have proved:

Theorem 1.5. *There are non-flat complete minimal surfaces in E^3 entirely contained in a slab.*

It is a well-known fact that every minimal surface F^2 can be represented in the form

$$x_k = \text{Re} \int \phi_k dz + c_k, \quad k = 1, 2, 3$$

where

$$\phi_1 = \frac{f}{2}(1-g^2), \quad \phi_2 = i \frac{f}{2}(1+g^2), \quad \phi_3 = fg.$$

Here f and g are holomorphic functions in the disc D and f vanishes nowhere. The metric of F^2 has the isothermal form: $ds^2 = \lambda^2 |dz|^2$ and

$$\lambda = \frac{|f|}{2}(1+|g|^2).$$

Let $g = \frac{1}{f}$, then $\phi_3 = 1$ and

$$x_3 = \text{Re} \int dz + c_3,$$

and consequently $|x_3| < \text{const}$. To obtain the completeness of F^2 one takes the function g in a special form. In this case

$$\lambda = \frac{1}{2} \left(|g| + \frac{1}{|g|} \right) \geq 1.$$

Let α is a curve in the disc D going to the boundary of D .

We shall distinguish two cases.

1. The Euclidean length of α is infinite.

Then the image of this curve on F^2 has the length

$$l(\alpha) = \int_0^{\infty} \lambda(\alpha(t)) dt = \infty.$$

2. The Euclidean length of α is a finite number b .

Let $g = e^h$ where h is some holomorphic function in D which is close to the positive number c_n on special subset $K_n \subset D$. The subset K_n has the form of circular annulus centered at the origin without some little pieces (see Fig. 1). In connection with the evenness or oddness of the number n , one takes this piece from different sides of annulus. Let $E = \cup_n^{\text{even}} K_n$ and $O = \cup_n^{\text{odd}} K_n$. The boundaries of K_n for $n \rightarrow \infty$ approximate the boundary of D . The following is true:

Any divergent path in D is either of finite Euclidean length will be such that: (a) cross all with the exception of a finite number K_n in E or (b) cross all with the exception of a finite number K_n in O .

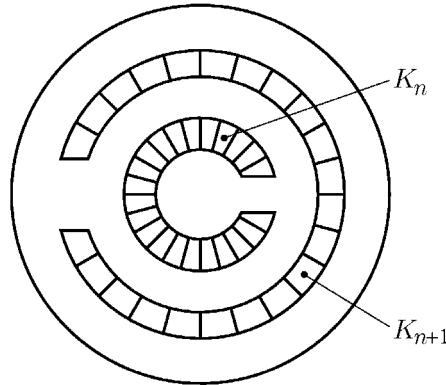

Figure 1

We take a sequence $c_n \rightarrow \infty$. The possibility to approximate this sequence by the function h follows from the theory of analytic functions [7]. We can suppose that $|h - c_n| < 1$ on K_n .

In the case (a) let m is a such integer, then α crosses all $K_n \in E$ with $n \geq m$. We put $g = e^h = e^{c_n} e^{h-c_n}$, then $|g| \geq e^{c_n-1}$. Let J_n is the set of all points t with $\alpha(t) \in K_n$. Then

$$2l(\alpha) \geq \int_0^b |g(\alpha(t))| dt \geq \sum_{n \geq m, n \text{ even}} \int |g(\alpha(t))| dt$$

is an arbitrary isometric minimal immersion and assume that $\phi(S_k^2)$ is not contained in a hyperplane of E^{l+1} . Then, modulo of a rigid motion

$$\phi = \psi_{2,s}$$

for some s .

In [8] do Carmo and Wallach have associated with each positive integer s an isometric minimal immersion

$$\psi_{n,k}: S_{k(s)}^n \rightarrow S_1^{m(s)},$$

with

$$k(s) = \frac{n}{s(s+n-1)},$$

$$m(s) = (2s+n-1) \frac{(s+n-2)!}{s!(n-1)!} - 1.$$

2. The Second Variation of the Area of a Minimal Surface in the Euclidean Space E^3

For a minimal surface in the 3-dimensional Euclidean space, the phenomenon of instability was considered in the XIX century by H. A. Schwarz. He have obtained the conditions of stability of a region on a minimal surface and constructed a number of examples.

The expression for the second variation of the area of a minimal surface F^2 with fixed boundary is

$$\delta^2 S = \int_G [2Kw^2 + |\text{grad } w|^2] dS.$$

As in the previous Section the variation of the minimal surface has the form

$$\bar{r} = r + \varepsilon w \xi,$$

where ξ is the unit normal to F^2 and $\varepsilon > 0$ is a constant. He have obtained also more general expression for the variation with a boundary which can move on the given surface.

Now we consider the variations with a fixed boundary.

We call the minimal surface F^2 **unstable** if in some neighborhood of F^2 there exists a surface \bar{F} with the same boundary and with lesser area.

As ordinary this definition can be substituted with the condition about the second variation:

- If $\delta^2 S \geq 0$, then we call F^2 a **stable** minimal surface.

- If $\delta^2 S < 0$ for some variation, then F^2 is unstable.

Because $KdS = d\omega$ is the element of the spherical image on the unit sphere, Schwarz presents $\delta^2 S$ in the following form

$$\delta^2 S = - \int_{\psi(G)} (\nabla_2^* w + 2w)w \, d\omega,$$

where $\psi: F^2 \rightarrow S^2$ is the spherical map. Here ∇_2^* is the Laplace–Beltrami operator of the unit sphere.

So, we can reformulate the problem of stability in terms of the spectral problem

$$\nabla_2^* w + 2\lambda w = 0$$

with the condition

$$w|_{\partial\psi(G)} = 0.$$

The classical result of Schwarz is following:

Some region G on the minimal surface $F^2 \subset E^3$ is stable if the first proper number λ_1 of ∇_2^ in the domain $\psi(G)$ obeys $\lambda_1 > 1$. If $\lambda_1 < 1$, then G is unstable.*

This theorem has only one defect that its formulation has non-geometric terms. By extending Schwarz' result the Brazilian geometers do Carmo and Barbosa [9] obtain a criterion of stability in terms of the area of the spherical image. The formulation is very simple:

Theorem 2.1. *If the area of the spherical image is less than 2π , then G is stable.*

For example, every domain on the minimal surface $z = z(x, y)$ is stable.

Do Carmo and Peng have considered the stability of complete minimal surfaces [10]. They have called a complete minimal surface stable if any of its compact region is stable and have proved the following theorem

Theorem 2.2. *If F^2 is a complete stable minimal surface in E^3 , then F^2 is a plane.*

In [11] Pogorelov have obtained a simple proof of this theorem for simple connected surface. At first, he have obtained the condition for unstability of geodesic disc $D(\rho)$ with the radius ρ on the minimal surface.

Let $C(\xi)$ is a geodesic circle with radius ξ and some center.

Theorem 2.3. (Pogorelov) *A simple connected minimal surface is unstable if there exists on it a geodesic disc with radius ρ for which is fulfilled one of the following conditions:*

1. $|\omega(\xi)| > \frac{l(\rho)}{2\rho \ln(\rho/\xi)}$ for some $\xi < \rho$;
2. $S(\rho) > \frac{4\pi\rho^2}{3}$

where $l(\rho)$ is the length of the circle $C(\rho)$, $S(\rho)$ is the area of the disc $D(\rho)$, and ω is the integral curvature of $D(\xi)$.

Let us consider the proof of do Carmo and Peng of the theorem with the help of Pogorelov's theorem.

Suppose that F^2 is stable and let its Gauss curvature K is not 0 at all points. Construct geodesic discs $D(\rho)$ with some center O . For enough large ξ we have $\omega(\xi) \neq 0$. Consider the ratio $l(\rho)/\rho$ for $\rho \rightarrow \infty$. If $\frac{l(\rho)}{\rho} < \text{const}$ for $\rho \rightarrow \infty$, then for a fixed ξ we have $\frac{l(\rho)}{\rho \ln(\rho/\xi)} \rightarrow 0$. For enough large ρ the first condition is true and therefore F^2 is unstable.

If now $\frac{l(\rho)}{\rho} \rightarrow \infty$ for $\rho \rightarrow \infty$ then

$$\frac{S}{\rho^2} = \frac{1}{\rho^2} \int_0^\rho l(\rho_1) d\rho_1 \leq \frac{N}{\rho^2} \int_{\rho_0}^\rho \rho_1 d\rho_1 = \frac{N(\rho^2 - \rho_0^2)}{2\rho^2} \rightarrow \infty,$$

where N is an arbitrary large number.

Therefore for enough large ρ the second condition is true and hence the surface is unstable. We obtain contradiction assuming that $K \neq 0$. Hence K is identically 0. With the condition $H = 0$ we conclude that F^2 is plane.

The article [17] by Kljachin and Miklukov provides a generalization of the Pogorelov's theorem for minimal hypersurfaces in Euclidean space.

Let M^n is a minimal hypersurface in E^{n+1} and $B(r)$ is geodesic ball with radius r and the center at the point $m_0 \in M$, let $l(r)$ is $(n-1)$ -dimensional Hausdorff measure of the boundary $\partial B(r)$, and let S is the scalar curvature of M^n . If there exist ρ_0 and ρ such that $0 < \rho_0 < \rho$ and

$$\int_{B(\rho_0)} |S| dV > \frac{(n-2)l(\rho)}{\rho^{n-1}} \frac{(\rho/\rho_0)^{n-2}}{(\rho/\rho_0)^{n-2} - 1}$$

for $n > 2$, then M^n is unstable.

3. On the Stability of Minimal Surfaces in the Riemannian Spaces

Between Differential Geometry and Topology there exist interesting and important connections. The first examples of such kind is the Gauss–Bonnet formula

$$2\pi\chi = \int_{F^2} K \, dS,$$

where F^2 is a closed oriented surface, and χ is Euler characteristics.

Another classical example is the well-known theorem “about the sphere”. It states that n -dimensional orientable complete simple connected Riemannian manifold with sectional curvature K_σ and satisfying the condition $\frac{1}{4} < K_\sigma \leq 1$ is homeomorphic to n -dimensional sphere S^n (Rauch, Berger, Toponogov, Klingenberg).

Next example is provided by Preismann: *On the product of 2 Riemannian manifolds $M \times N$ does not exist a metric with a negative sectional curvature*.

Very close to this statement is the hypothesis of Hopf that can be formulated in the following way: *On the topological product of two 2-dimensional spheres $S^2 \times S^2$ does not exist a metric with a positive sectional curvature*.

We remark that this is the first one within the line of problems about permissible metrics on the topological products.

Many geometers were trying to solve this question. An interesting results were obtained by Berger, Bourguignon, Sentenac and others. One can approach this problem from different directions. The geodesic curves are playing the most important role in the proof of the theorem “about the sphere”.

Because the second homotopic group of $S^2 \times S^2$ is not trivial, I had an intention to use the theory of the stability of minimal surfaces to this problem. It was in 1975 when I have proved the following theorem.

Theorem 3.1. *If F^2 is a minimal surface homeomorphic to the sphere S^2 and lies in an oriented simple connected Riemannian space M^n with a sectional curvature $\frac{1}{4} < K_\sigma \leq 1$. Then F^2 is unstable.*

Here we see that the lower boundary of the curvature of the Riemannian space is $\frac{1}{4}$. And this restriction is essential. In 4-dimensional projective space $\mathbb{C}\mathbb{P}^2$ with the Fubini–Study metric there exist totally geodesics and stable surfaces. Let us remark, that the curvature K_σ of this metric lies in the interval $\left[\frac{1}{4}, 1\right]$. Here the boundary numbers of the interval are included. In some cases for

special classes of M^n we can throw away the restrictions on the curvature of M^n .

Theorem 3.2. *Let F^2 is a minimal surface homeomorphic to the sphere S^2 and situated in an n -dimensional orientable locally conformally flat space M^n of positive curvature. Suppose that the normal bundle of F^2 is trivial, then F^2 is an unstable minimal surface.*

The triviality of normal bundle means that we can construct on the whole F^2 $n - 2$ normal regular fields.

Theorem 3.3. *A complete geodesic surface homeomorphic to a sphere, having a regular field of unit normals and situated in a symmetric orientable manifold M^4 of positive curvature, is unstable.*

The appearance of such kind theorem implies the next step: the existence of stable minimal surface as consequence of topological restrictions on M^4 . Such theorems of existence belong to Schoen and Yau [12] and Sacks and Uhlenbeck [13]. The first two authors used this approach in the investigation of 3-dimensional compact Riemannian spaces with positive scalar curvature.

Then Micallef and Moore [15] using the same approach have obtained the generalization of the theorem “about the sphere”.

Now I want to give a short summary of the proof of Theorem 1.

Let F^2 is a minimal surface in the Riemannian space M^n , ξ_1, \dots, ξ_{n-2} is the field of orthonormal basis of its normal spaces. $\mu_{k\rho|\alpha}$ are the coefficients of torsion of this basis, k_j^ρ is the j -th principal curvature with respect to the normal vector ξ_ρ . $K(e_i, \xi)$ is the curvature of the space M^n over the element of area traced by ξ and a vector e_i from the orthonormal basis in the tangent space.

We write the expression for the second variation of the area obtained by varying the field $w\xi_\rho$ as

$$\delta^2 S(\xi_\rho) = \int_{F^2} \left[|\text{grad } w|^2 + \sum_j \mu_{j\rho|\alpha} \mu_{j\rho}^\alpha - w^2 \left(- \sum_{i \neq j} k_i^\rho k_j^\rho + \sum_{i=1}^2 K(e_i, \xi_\rho) \right) \right] dS.$$

Simons wrote the sum of the first two terms in the form $\langle \nabla \xi \nabla \xi \rangle$, where ∇ is the covariant derivative in the normal bundle.

Then I consider two variations $V_1 = w\xi_1$, $V_2 = w\xi_2$, where w is some regular of the class C^1 function on F^2 and ξ_1, ξ_2 are orthogonal between themselves

unit vector fields that are normal to F^2 . We take the sum

$$\delta^2 S(V_1) + \delta^2 S(V_2).$$

This sum is reducible to a form which is more convenient for us. Consider the expression of $\delta^2 S(V_1)$. By the well known theorem we can introduce always isothermal coordinates on F^2 with $ds^2 = \Lambda(du_1^2 + du_2^2)$ that satisfy the condition: $\Lambda \rightarrow 0$ as $\frac{1}{|z|^4}$, where $z = u_1 + iu_2$. We can rewrite $\langle \nabla V_1 \nabla V_1 \rangle$ in the form:

$$\begin{aligned} \langle \nabla V_1 \nabla V_1 \rangle = \Lambda^{-1} & \left[(w_{u^1} + w\mu_{12|2})^2 + (w_{u^2} - w\mu_{12|1})^2 \right. \\ & + \sum_{j=3}^{n-2} w^2 [(\mu_{1j|1})^2 + \mu_{1j|2}]^2 + (w^2 \mu_{12|1})_{u^2} - (w^2 \mu_{12|2})_{u^1} \\ & \left. + w^2 (\mu_{12|2,1} - \mu_{12|1,2})^2 \right]. \end{aligned}$$

The coefficients of the first and the second quadratic forms and the coefficients of torsion satisfy the Gauss–Codazzi–Ricci equations. Now we need only the Ricci equations:

$$\mu_{ml|2,1} - \mu_{ml|1,2} = (\kappa_{ml} + \sigma_{ml} + T_{ml})/\Lambda,$$

where

$$\begin{aligned} \kappa_{ml} &= g^{pq}(L_{m|p1}L_{l|q2} - L_{m|p2}L_{l|q1})/\Lambda, \\ \sigma_{ml} &= \sum_{p=1}^{n-2} (\mu_{pm|1}\mu_{pl|2} - \mu_{pm|2}\mu_{pl|1})/\Lambda, \\ T_{ml} &= R_{\beta\lambda\mu\nu}\xi_m^\beta \xi_l^\lambda y_{,1}^\mu y_{,2}^\nu / \Lambda. \end{aligned}$$

We substitute $\mu_{12|2,1} - \mu_{12|1,2}$ with the expression in the right side of Ricci equation. Similarly we transform $\langle \nabla V_2 \nabla V_2 \rangle$. Adding the two expressions we find that

$$\begin{aligned} \sum_{i=1}^2 \langle \nabla V_i \nabla V_i \rangle &= \frac{1}{\Lambda} \left[2(w_{u^1} + w\mu_{12|2})^2 \right. \\ &+ 2(w_{u^2} - w\mu_{12|1})^2 + w^2 \sum_{j=3}^{n-2} [(\mu_{1j|1} + \mu_{2j|2})^2 \\ &+ (\mu_{1j|2} - \mu_{2j|1})^2] + 2w^2 [\kappa_{12} + T_{12}] \\ &\left. + \frac{2}{\Lambda} [(w^2 \mu_{12|1})_{u^2} - (w^2 \mu_{12|2})_{u^1}] \right]. \end{aligned}$$

The integral of the last term over any region $D \subset F^2$ is transformed into an integral along the boundary, if it exists. If the boundary is empty, then this integral is transformed to zero. Later we consider the system of equations

$$\begin{aligned} w_{u^1} + w\mu_{12|2} &= 0, & \mu_{1j|1} + \mu_{2j|2} &= 0, \\ w_{u^2} - w\mu_{12|1} &= 0, & \mu_{1j|2} - \mu_{2j|1} &= 0, \\ j &= 3, \dots, n-2. \end{aligned}$$

By rotation of the basis of normals, this system can be represented in the form

$$2 \frac{\partial U_k}{\partial \bar{z}} = B_{km} U_m,$$

Thus we have proved the existence of non-trivial solution. Further we obtain

$$\sum_{i=1}^2 \delta^2 S(\xi_i) = \int w^2 [2\kappa_{12} - 2 \sum_{i=1}^2 |K_e(\xi_i)| + 2T_{12} - \sum_{i,j} K(e_i, \xi_j)] dS.$$

If the curvature of the Riemannian space satisfies the inequalities $\delta \leq k_\sigma \leq 1$, where $\delta = \text{const}$, then for the Riemannian tensor in orthogonal coordinates we have the inequalities of Berger

$$|R_{ijik}| \leq \frac{1}{2}(1 - \delta), \quad |R_{ijkl}| \leq \frac{2}{3}(1 - \delta).$$

It follows that $|T_{12}| \leq \frac{2}{3}(1 - \delta)$.

It is easy to show that, by virtue of the minimality

$$\begin{aligned} \sum_{i=1}^2 \delta^2 S(V_i) &= \int w^2 [2\kappa_{12} - 2 \sum_{i=1}^2 |K_e(\xi)| + 2T_{12} - \sum_{i,j} K(e_i, \xi_j)] dS \\ &\leq \int w^2 [\frac{4}{3}(1 - \delta) - 4\delta] dS < 0, \end{aligned}$$

since $\delta > \frac{1}{4}$. Therefore, F^2 is an unstable minimal surface.

Recently Pogorelov have obtained some new theorems about instability of minimal surfaces. He have proved that a minimal homeomorphic to 2-dimensional sphere surface F^2 in the product $S^2 \times S^n$ with $n > 2$ which has positive sectional curvature, is unstable [23].

4. The Behaviour of the Area of 2-Dimensional Surface in the Pseudo-Euclidean Spaces

In this Section I want to present the results of my pupil Victor Goroch from his article [16].

In the pseudo-Euclidean space $E^{n,k}$ we introduce coordinates x_1, \dots, x_n and the metric

$$ds^2 = dx_1^2 + \dots + dx_{n-k}^2 - dx_{n-k+1}^2 - \dots - dx_n^2.$$

Let $r = r(u, v)$ is the position vector of a surface V^2 . The area of V^2 is determined by the following expression

$$S(V^2) = \int_D \sqrt{|EG - F^2|} du dv,$$

where E, F, G are the coefficients of the first fundamental form of V^2 (classical notation). The Euclidean space E^n with the metric

$$ds_E^2 = dx_1^2 + \dots + dx_n^2$$

will be called **associated** with $E^{n,k}$.

Theorem 4.1. *Let L is a piecewise smooth closed curve in pseudo-Euclidean space $E^{n,k}$, $k \geq 1$. Then there exists 2-dimensional piecewise smooth surface with boundary L and infinitesimal area.*

I want to remark that in the mathematical physics one consider minimal surfaces and the solutions of other variation problems in pseudo-Euclidean space. For example, we can remind the Nambu's approach to the problem of non observability of quarks and the later developments in the theory of strings.

Lemma 4.1. *Let ABC is a triangle in $E^{3,1}$. Then there exists piecewise smooth surface with boundary ABC and infinitesimal area.*

Let E^2 is a tangent plane of the isotropic cone. If we introduce in $E^{3,1}$ a coordinate system with coordinates x, y, z , then the equation

$$(x - x_0)^2 + (y - y_0)^2 = (z - z_0)^2$$

represents an isotropic cone with a summit at (x_0, y_0, z_0) .

Then, the area of any region of this plane is equal to zero.

Let the point (a, b, c) lies on the cone and on the plane E^2 . The equation of the plane E^2 is

$$z - c = \frac{a - x_0}{c - z_0} x + \frac{(b - y_0)}{c - z_0} y + \frac{a(x_0 - a) + b(y_0 - b)}{c - z_0}.$$

The position vector of E^2 will be presented in the form

$$r = \begin{pmatrix} x \\ y \\ z(x, y) \end{pmatrix}.$$

We have

$$r_x = \begin{pmatrix} 1 \\ 0 \\ z_x \end{pmatrix}, \quad r_y = \begin{pmatrix} 0 \\ 1 \\ z_y \end{pmatrix}.$$

Then

$$E = r_x^2 = 1 - z_x^2, \quad F = -z_x z_y, \quad G = 1 - z_y^2,$$

$$EG - F^2 = 1 - z_x^2 - z_y^2 = 1 - \left(\frac{a - x_0}{c - z_0} \right)^2 - \left(\frac{b - y_0}{c - z_0} \right)^2 = 0.$$

In order to obtain the proof of the lemma we consider different positions of the triangle ABC .

1° Let the triangle ABC lies in the plane parallel to the plane x, y (Fig. 2). Inscribe in the triangle a circle and let the point O is the center of this circle and ρ is its radius. Let ON is a segment of straight line parallel to the z axis and let $|ON|$ is equal to ρ . Then all triangles NAC , NAB and NCB have the area equal to zero.

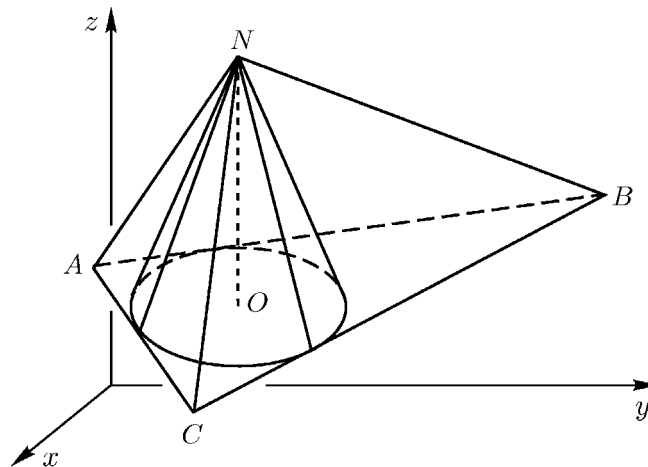

Figure 2

2° Let the triangle ABC lies in some other plane α parallel to the z axis (Fig. 3). Divide the plane α in euclidean infinitesimal squares with diagonals parallel to the z axis. Then every such square can be transformed into two conic surfaces built by isotropic straight lines. These surfaces have also areas equal to zero. We can inscribe in the triangle ABC many little squares and

then construct many conic surfaces. Therefore, we can construct a surface with boundary ABC and with an infinitesimal area.

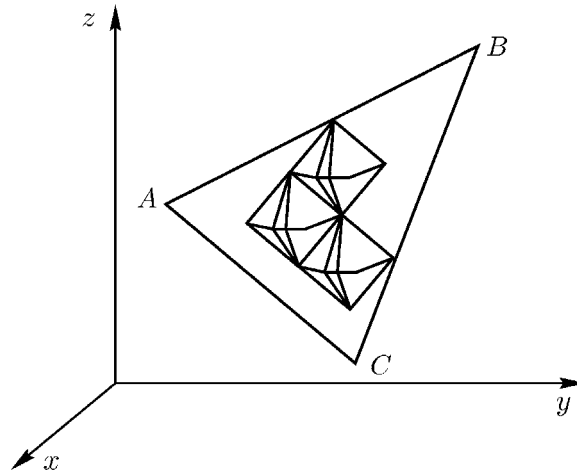

Figure 3

3° Let ABC is a triangle in an arbitrary plane α which is non-parallel to the z axis (Fig. 4). Let $X \in ABC$. Let r_X is a ray with origin X and parallel to the z axis. Let β is a plane parallel to the plane x, y that intersect all rays r_X . We obtain in the plane β a projection $A_1B_1C_1$ of the triangle ABC . Let Φ is a surface which is the union of AA_1C_1C , CC_1B_1B , AA_1B_1B and $A_1B_1C_1$.

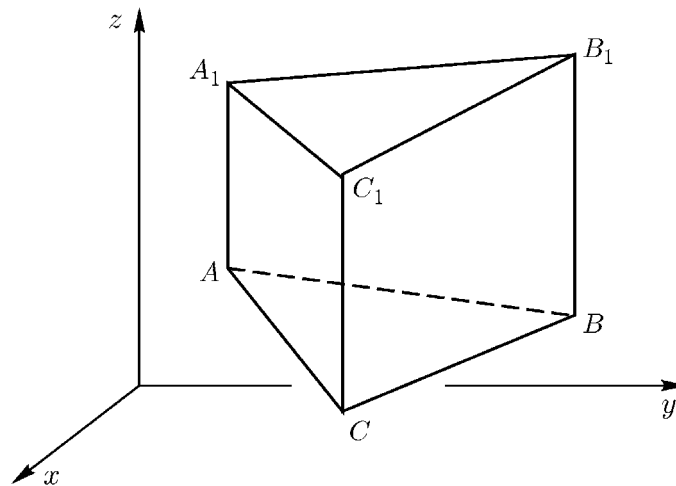

Figure 4

Every such region AA_1C_1C, \dots can be replaced by the surface with an infinitesimal area and with boundary ABC .

The following lemma will be stated without proof.

Lemma 4.2. *Let α is an 2-dimensional plane in $E^{n,k}$ and ABC is a triangle in the plane α . Then there exists a surface with boundary ABC and infinitesimal area.*

Let us prove firstly Theorem 4.1.

Divide the curve L by points A_0, \dots, A_{n-1} in n equal arcs in the euclidean metric. Let X is an arbitrary point on the arc $A_i A_{i+1}$. We take a surface that consists of the points of all segments $A_i X$. Its boundary is the arc $A_i A_{i+1}$ and straight line segment $A_i A_{i+1}$. Denote this surface by Φ_i .

Let ε is an arbitrary positive number. Let l is the euclidean length of the curve L . Then the euclidean length of $A_i A_{i+1}$ is $\frac{l}{n}$. Let Φ_i^* is the surface consisting from the points of the surface Φ_i but viewed as the surface in the associated space E^n . The surface Φ_i^* is a cone in E^n , then the area of Φ_i^* is less or equal to $\frac{l^2}{4\pi}$. So $S(\Phi) \leq \frac{l^2}{4\pi}$, or $S(\Phi_i) \leq \frac{l^2}{\pi n^2}$. Let us take $n > \frac{2l^2}{4\varepsilon}$. Then $S(\Phi_i) \leq \frac{\varepsilon}{2n-2}$.

Consider now the surface which consists of the triangles $\Delta_i = A_0 A_i A_{i+1}$, $i = 1, \dots, n-2$. Its boundary is the closed broken line A_0, A_1, \dots, A_{n-1} . By the Lemma 4.2 for every such triangle Δ_i there exists a surface V_i with the same boundary and area $S(V_i) < \frac{\varepsilon}{2n-2}$. Then the union of all surfaces

$$V_1, V_2, \dots, V_{n-2}, \Phi_1, \dots, \Phi_n$$

is a piecewise smooth surface Φ with area $S(\Phi) \leq \varepsilon$ and with boundary L . Theorem 4.1 is proved.

Let $\rho(u)$ is the position vector of the curve L in the pseudo-Euclidean space $E^{3,1}$ and $\xi(u)$ is a vector field along L .

We call the surface with the position vector $r(u, v) = \rho(u) + v\xi(u)$, $-\varepsilon < v < \varepsilon$ a regular strip.

Let us ask the question: *Does there exist a regular strip through L with area equal to zero?*

Theorem 4.2. *Let L is a closed regular curve in $E^{3,1}$. For existence of a regular strip with area equal to zero over L it is necessary and sufficient that the tangent vector at every point of L is not time-like.*

Now I want to consider the question of stability of minimal surfaces in pseudo-Euclidean space following [17].

The plane in $E^{3,1}$ is called **space-like** plane if in this plane there exists an orthogonal basis e_1, e_2 with $e_1^2 > 0$, $e_2^2 > 0$. A surface in $E^{3,1}$ will be called space-like if its tangent plane is space-like.

We call the surface in $E^{3,1}$ with zero mean curvature a minimal surface.

Theorem 4.3. *Any piece of a space-like minimal surface in $E^{3,1}$ represented by*

$$z = z(x, y)$$

has the largest area among the closed space-like surfaces with the same boundary.

We remark that such a representation has any space-like surface.

The surface is **time-like** if in its tangent plane we can take vectors e_1, e_2 with $e_1^2 > 0$ and $e_2^2 < 0$.

Theorem 4.4. *Let V^2 is a time-like minimal surface in $E^{3,1}$. Then for any region of V^2 there exists a smooth variation in the class of time-like surfaces with a fixed boundary which decreases the area and there exists a variation which increases the area.*

For the proof we use the following lemmas.

Lemma 4.3. *Let V^2 is a 2-dimensional smooth time-like surface in pseudo-Euclidean space $E^{n,1}$ $n \geq 3$. Then in the neighborhood of an arbitrary point of V^2 it is possible to introduce isothermal coordinates $ds^2 = \lambda(u, v)(du^2 - dv^2)$.*

We take the variation of V^2 in the form

$$r(u, v, \varepsilon) = r(u, v) + \varepsilon n(u, v) \xi(u, v),$$

where $\xi(u, v)$ is an unit normal of F^2 and $n(u, v)$ is a regular function of the class C^2 .

Lemma 4.4. *The second variation of the area of V^2 has the form*

$$\delta^2 S = \int (2n^2 K + \nabla_1 n) dS,$$

where

$$\nabla_1 n = \frac{En_v^2 - 2Fn_u n_v + Gn_u^2}{EG - F^2}$$

is the first differential parameter of Beltrami.

In the plane u, v we take the square ω : $-\eta \leq u \leq \eta$, $-\eta \leq v \leq \eta$. If we put

$$n(u, v) = \left(1 + \cos \frac{(2m+1)\pi}{\eta} u\right) \left(1 + \cos \frac{\pi}{\eta} v\right),$$

then for enough large m we obtain: $\delta^2 S > 0$.

For

$$n(u, v) = \left(1 + \cos \frac{\pi}{\eta} u\right) \left(1 + \cos \frac{(2m+1)\pi}{\eta} v\right)$$

and for large m we obtain: $\delta^2 S < 0$.

Theorem 4.5. *Let L is a closed curve in the plane y, z . Then there exists a surface with boundary L and area larger than an arbitrary given number.*

For example, if L is a boundary of the rectangle: $-\varepsilon \leq y \leq \varepsilon$, $-3\varepsilon \leq z \leq 3\varepsilon$, then we can take the surface in the form $x = f(z, y)$, where

$$f(z, y) = \frac{\varepsilon}{\pi} \left(1 + \cos \frac{(2m+1)\pi y}{\varepsilon}\right) \left(1 + \cos \frac{\pi z}{3\varepsilon}\right).$$

Then the area is equal to the number

$$S_1 = \frac{24\varepsilon^2(2m+1)}{\pi^2}.$$

For an arbitrary given large number N we can take a large number m such that the area S will be larger than this number N . The Theorem 4.5 is proved.

In [18] Kljachin and Miklukov have considered the second variation of the minimal submanifolds in pseudo-Riemannian manifolds. For space-like submanifolds F^n they have proved that the variation of F^n in the time-like direction ξ does not increase the area and F^n is maximal in the direction ξ .

If η is space-like direction (this case is possible only for $\text{codim} > 1$), then the variation in the direction of η does not decrease the area. The submanifold in the direction η is locally minimal.

In the article by Shen [19] it is proved that an arbitrary space-like submanifold V^k with a mean curvature vector equal to zero in a pseudo-Riemannian manifold M^n of non-negative sectional curvature is stable. If M^n is a complete simple connected manifold with constant non-negative curvature and if V^n is complete, then M is totally geodesic.

In the article by Kljachin and Miklukov [20] it is proved that an arbitrary stable minimal hypersurface of parabolic type in the Riemannian space of non-negative Ricci curvature is totally geodesic.

The expression (5.2) is very convenient for computer calculations when the representation of the submanifold is given by some system of analytical equations. Let the system (5.1) consists of only two equations

$$\begin{aligned}\Phi_1(x^1, \dots, x^n) &= 0, \\ \Phi_2(x^1, \dots, x^n) &= 0.\end{aligned}$$

In the sequel it is convenient to use the following notation

$$M_{rlsn} = \frac{1}{2} \begin{vmatrix} \Phi_{\beta|rs} & \Phi_{\beta|ls} \\ \Phi_{\alpha|rn} & \Phi_{\alpha|ln} \end{vmatrix} a^{\alpha\beta}.$$

Define the vectors

$$\sigma_{rs} = \Phi_{1|rs} \text{grad } \Phi_2 - \Phi_{2|rs} \text{grad } \Phi_1.$$

Then

$$M_{rlsn} = \frac{1}{4\Delta} [(\sigma_{rs}\sigma_{ln} - (\sigma_{rn}\sigma_{ls}))],$$

where $\Delta = |[\text{grad } \Phi_1 \text{grad } \Phi_2]|$ is the norm of the corresponding bivector.

The formula is further simplified in the case of a 2-dimensional surfaces in E^4 . We put $\Phi_1 = \Phi$, $\Phi_2 = \Psi$. Let the equations of $F^2 \subset E^4$ have the form

$$\Phi(x_1, \dots, x_4) = 0, \quad \Psi(x_1, \dots, x_4) = 0. \quad (5.3)$$

Let us arrange all pairs of distinct indices i and l in the order

$$(12), (13), (14), (23), (24), (34).$$

Thus to each of these pairs we assign number α indexing the position of this pair in the above list. We introduce the symmetric matrix A with entries $A_{\alpha\beta} = 4\Delta M_{iljk}$, where α corresponds to the pair il and β corresponds to jk . Let us take the bivector $d = [\text{grad } \Phi \text{grad } \Psi]$ and q is the complementary to d bivector. We consider these bivectors as vectors in the space E^6 . Then we have the following theorem

Theorem 5.2. *The Gauss curvature K of the surface $F^2 \subset E^4$ given by the system of equations (5.3) can be expressed by the formula*

$$K = \frac{(qAq)}{|q|^4}.$$

The condition $\Delta \neq 0$ is sufficient for the regularity of F^2 . But we remark that not all closed surfaces have the representation in the form (5.3). Really, under the condition $\Delta \neq 0$ the vectors $\text{grad } \Phi$ and $\text{grad } \Psi$ form a basis in the normal space for $F^2 \in E^4$. So, the surface $F^2 \in E^4$ with non-zero Whitney invariant

has not a representation in the form (5.3). We have constructed such kind of surfaces in [22].

Acknowledgement

The participation of the author at this conference is supported partially by the Polish Committee for Scientific Research KBN, grant 2 PO3B 143 15 and European Mathematical Society.

References

- [1] Chern S. S., *The Geometry of G-Structures*, Bull. Amer. Math. Soc. **72** (1966) 167–219.
- [2] Aminov Yu., *Exterior Diameter of Immersed Riemannian Space* (in Russian), Mat. Sb. **92** (1973) 456–460.
- [3] Hasanis Th. and Koutroufiotis D., *Immersion of Bounded Mean Curvatures*, Arch. Math. **33** (1979) 170–171.
- [4] Omori H., *Isometric Immersions of Riemannian Manifolds*, J. Math. Soc. Japan **19** (1967).
- [5] Jorge L. and Xavier F., *A Complete Minimal Surfaces in \mathbb{R}^3 Between Two Parallel Planes*, Ann. of Math. **112** (1980) 203–206.
- [6] Jorge L. and Xavier F., *On the Existence Complete Bounded Minimal Surfaces*, Bull. Soc. Brazil Math. **10** (1979).
- [7] Hoffman K., *Banach Spaces of Analytic Functions*, Prentice-Hall Inc., Englewood Cliffs, N.J. 1962.
- [8] Do Carmo M. and Wallach N., *Minimal Immersions of Spheres into Spheres*, Ann. Math. **93** (1971) 43–62.
- [9] Barbosa J. L. and do Carmo M., *On the Size of a Stable Minimal Surface in \mathbb{R}^3* , Amer. J. Math. **98** (1976).
- [10] Do Carmo M. and Peng S. K., *The Stable Minimal Surfaces in \mathbb{R}^3 are Plane*, Bull. Amer. Math. Soc. **1** (1979) 903–906.
- [11] Pogorelov A. V., *On the Stability of Minimal Surfaces* (in Russian), Doklady of the Soviet Academy of Sciences **260** (1981) 293–295.
- [12] Schoen R. and Yau S. T., *Existence of Incompressible Minimal Surface and the Topology of Three Dimensional Manifolds with Non-negative Scalar Curvature*, Ann. Math. **110** (1979) 127–142.
- [13] Sacks J. and Uhlenbeck K., *The Existence of Minimal Immersions of 2-Spheres*, Ann. Math. **2** (1981) 1–24.
- [14] Aminov Yu. A., *On the Instability of a Minimal Surface in an n -Dimensional Riemannian Space of Positive Curvature* (in Russian), Math. USSR Sbornik **29** (1976) 359–375.
- [15] Micallef M. J. and Moore J. D., *Minimal Two-spheres and the Topology of Manifolds with Positive Curvature on Totally Isotropic Two-planes*, Ann. Math. **127** (1988) 199–227.

- [16] Goroch V., *On the Minimum of Area of Surface with Given Boundary in Pseudo-Euclidean Space* (in Russian), Ukrain. Geom. Sb. **30** (1987) 18–22.
- [17] Goroch V., *On the Stability of Minimal Surface in Pseudo-Euclidean Space* (in Russian), Ukrain. geom. Sb. **33** (1990) 41–45.
- [18] Kljachin V. A. and Miklukov V. M., *The Signs of Instability of Surfaces with Zero Mean Curvature in Curved Lorentzian Spaces* (in Russian), Math. Sb. **187** (1996) 67–88.
- [19] Shen Y., *On Maximal Submanifolds in Pseudo-Riemannian Manifolds*, J. Hangzhou Univ. Natur. Sci. Ed., **18** (1991) 371–376.
- [20] Kljachin V. A. and Miklukov V. M., *About One Capacity Sign of Instability of Minimal Hypersurfaces* (in Russian), Doklady of the Soviet Academy of Sciences **330** (1993) 424–426.
- [21] Aminov Yu., *Expression of the Riemann Tensor of a Submanifold Defined by a System of Equations in Euclidean Space*, Math. Notes **6** (1999) 3–7.
- [22] Aminov Yu. and Manschos N., *The Closed Surfaces in E^4 with Nonzero Invariant Whitney* (in Russian), Math. Physics, Analysis, Geometry, **5** (1998) 139–148.
- [23] Pogorelov A. V., *On the one Hopf Problem* (in Russian), Doklady of the Russian Academy of Sciences **372** (2000) 593–595.