

A construction of pseudo-Anosov braids with small normalized entropies

Susumu Hirose and Eiko Kin

ABSTRACT. Let b be a pseudo-Anosov braid whose permutation has a fixed point and let M_b be the mapping torus by the pseudo-Anosov homeomorphism defined on the genus 0 fiber F_b associated with b . We prove that there is a 2-dimensional subcone \mathcal{C}_0 contained in the fibered cone \mathcal{C} of F_b such that the fiber F_a for each primitive integral class $a \in \mathcal{C}_0$ has genus 0. We also give a constructive description of the monodromy $\phi_a : F_a \rightarrow F_a$ of the fibration on M_b over the circle, and consequently provide a construction of many sequences of pseudo-Anosov braids with small normalized entropies. As an application we prove that the smallest entropy among skew-palindromic braids with n strands is comparable to $1/n$, and the smallest entropy among elements of the odd/even spin mapping class groups of genus g is comparable to $1/g$.

CONTENTS

1. Introduction	563
2. Preliminaries	568
3. i -increasing braids and Theorem 3.2	572
4. Proof of Theorem 3.2	575
5. Sequences of pseudo-Anosov braids with small normalized entropies	583
6. Stable foliation for the monodromy	584
7. Properties of F -surfaces and E -surfaces	586
8. Application	589
References	595

Received April 6, 2019.

2010 *Mathematics Subject Classification.* 57M99, 37E30.

Key words and phrases. mapping class groups, pseudo-Anosov, dilatation, normalized entropy, fibered 3-manifolds, braid group.

We would like to thank Mitsuhiko Takasawa for helpful conversations and comments. The first author was supported by Grant-in-Aid for Scientific Research (C) (No. 16K05156), Japan Society for the Promotion of Science. The second author was supported by Grant-in-Aid for Scientific Research (C) (No. 18K03299), Japan Society for the Promotion of Science.

1. Introduction

Let $\Sigma = \Sigma_{g,n}$ be an orientable surface of genus g with n punctures for $n \geq 0$. We set $\Sigma_g = \Sigma_{g,0}$. By mapping class group $\text{Mod}(\Sigma_{g,n})$, we mean the group of isotopy classes of orientation preserving self-homeomorphisms on $\Sigma_{g,n}$ preserving punctures setwise. By Nielsen-Thurston classification, elements in $\text{Mod}(\Sigma)$ are classified into three types: periodic, reducible, pseudo-Anosov [30, 9]. For $\phi \in \text{Mod}(\Sigma)$ we choose a representative $\Phi \in \phi$ and consider the mapping torus $M_\phi = \Sigma \times \mathbb{R} / \sim$, where \sim identifies $(x, t + 1)$ with $(\Phi(x), t)$ for $x \in \Sigma$ and $t \in \mathbb{R}$. Then Σ is a fiber of a fibration on M_ϕ over the circle S^1 and ϕ is called the *monodromy*. A theorem by Thurston [31] asserts that M_ϕ admits a hyperbolic structure of finite volume if and only if ϕ is pseudo-Anosov.

For a pseudo-Anosov element $\phi \in \text{Mod}(\Sigma)$ there is a representative $\Phi : \Sigma \rightarrow \Sigma$ of ϕ called a *pseudo-Anosov homeomorphism* with the following property: Φ admits a pair of transverse measured foliations (\mathcal{F}^u, μ^u) and (\mathcal{F}^s, μ^s) and a constant $\lambda = \lambda(\phi) > 1$ depending on ϕ such that \mathcal{F}^u and \mathcal{F}^s are invariant under Φ , and μ^u and μ^s are uniformly multiplied by λ and λ^{-1} under Φ . The constant $\lambda(\phi)$ is called the *dilatation* and \mathcal{F}^u and \mathcal{F}^s are called the *unstable* and *stable foliation*. We call the logarithm $\log(\lambda(\phi))$ the *entropy*, and call

$$\text{Ent}(\phi) = |\chi(\Sigma)| \log(\lambda(\phi))$$

the *normalized entropy* of ϕ , where $\chi(\Sigma)$ is the Euler characteristic of Σ . Such normalization of the entropy is suited for the context of 3-manifolds [8, 22].

Penner [27] proved that if $\phi \in \text{Mod}(\Sigma_{g,n})$ is pseudo-Anosov, then

$$\frac{\log 2}{12g - 12 + 4n} \leq \log(\lambda(\phi)). \tag{1.1}$$

See also [22, Corollary 2]. For a fixed surface Σ , the set

$$\{\log \lambda(\phi) \mid \phi \in \text{Mod}(\Sigma) \text{ is pseudo-Anosov}\}$$

is a closed, discrete subset of \mathbb{R} ([1]). For any subgroup or subset $G \subset \text{Mod}(\Sigma)$ let $\delta(G)$ denote the minimum of $\lambda(\phi)$ over all pseudo-Anosov elements $\phi \in G$. Then $\delta(G) \geq \delta(\text{Mod}(\Sigma))$. We write $f \asymp h$ if there is a universal constant $P > 0$ such that $1/P \leq f/h \leq P$. It is proved by Penner [27] that the minimal entropy among pseudo-Anosov elements in $\text{Mod}(\Sigma_g)$ on the closed surface of genus g satisfies

$$\log \delta(\text{Mod}(\Sigma_g)) \asymp \frac{1}{g}.$$

See also [16, 32, 33] for other sequences of mapping class groups.

For any $P > 0$, consider the set Ψ_P consisting of all pseudo-Anosov homeomorphisms $\Phi : \Sigma \rightarrow \Sigma$ defined on any surface Σ with the normalized entropy $|\chi(\Sigma)| \log \lambda(\Phi) \leq P$. This is an infinite set in general (take $P > 2 \log(2 + \sqrt{3})$ for example) and is well-understood in the context of

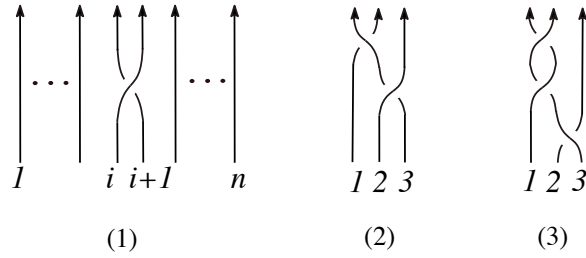

FIGURE 1. (1) σ_i . (2) $\sigma_1^{-1}\sigma_2$ with the permutation $1 \mapsto 2$, $2 \mapsto 3$, $3 \mapsto 1$. (3) $\sigma_1^2\sigma_2^{-1}$ whose permutation has a fixed point.

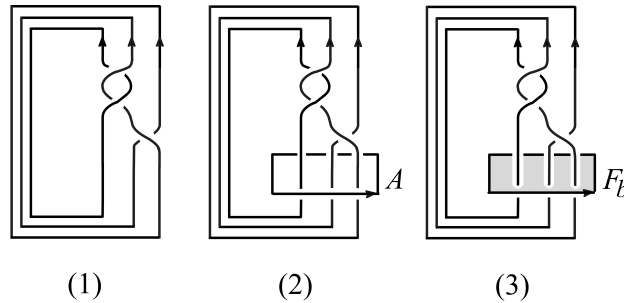

FIGURE 2. $b := \sigma_1^2\sigma_2^{-1}$. (1) $\text{cl}(b)$. (2) $\text{br}(b)$. (3) $F_b \hookrightarrow M_b$.

hyperbolic fibered 3-manifolds. The universal finiteness theorem by Farb-Leininger-Margalit [8] states that the set of homeomorphism classes of mapping tori of pseudo-Anosov homeomorphisms $\Phi^\circ : \Sigma^\circ \rightarrow \Sigma^\circ$ is finite, where $\Phi^\circ : \Sigma^\circ \rightarrow \Sigma^\circ$ is the fully punctured pseudo-Anosov homeomorphism obtained from $\Phi \in \Psi_P$. (Clearly $\lambda(\Phi^\circ) = \lambda(\Phi)$.) In other words such $\Phi^\circ : \Sigma^\circ \rightarrow \Sigma^\circ$ is a monodromy of a fiber in some fibered cone for a hyperbolic fibered 3-manifold in the finite list determined by P . Thus 3-manifolds in the finite list govern all pseudo-Anosov elements in Ψ_P . It is natural to ask the dynamics and a constructive description of elements in Ψ_P . There are some results about this question by several authors [4, 15, 20, 21, 33], but it is not completely understood. In this paper we restrict our attention to the pseudo-Anosov elements in Ψ_P defined on the genus 0 surfaces, and provide an approach for a concrete description of those elements.

Let B_n be the braid group with n strands. The group B_n is generated by the braids $\sigma_1, \dots, \sigma_{n-1}$ as in Figure 1. Let \mathcal{S}_n be the symmetric group, the group of bijections of $\{1, \dots, n\}$ to itself. A permutation $\mathcal{P} \in \mathcal{S}_n$ has a *fixed point* if $\mathcal{P}(i) = i$ for some i . We have a surjective homomorphism $\pi : B_n \rightarrow \mathcal{S}_n$ which sends each σ_j to the transposition $(j, j + 1)$.

The closure $\text{cl}(b)$ of a braid $b \in B_n$ is a knot or link in the 3-sphere S^3 . The *braided link*

$$\text{br}(b) = \text{cl}(b) \cup A$$

is a link in S^3 obtained from $\text{cl}(b)$ with its braid axis A (Figure 2). Let M_b denote the exterior of $\text{br}(b)$ which is a 3-manifold with boundary. It is easy to find an $(n + 1)$ -holed sphere F_b in M_b (Figure 2(3)). Clearly F_b is a fiber of a fibration on $M_b \rightarrow S^1$ and its monodromy $\phi_b : F_b \rightarrow F_b$ is determined by b . We call F_b the *F-surface* for b .

A braid $b \in B_n$ is *periodic* (resp. *reducible*, *pseudo-Anosov*) if the associated mapping class $f_b \in \text{Mod}(\Sigma_{0,n+1})$ is of the corresponding type (Section 2.3). If b is pseudo-Anosov, then the *dilatation* $\lambda(b)$ is defined by $\lambda(f_b)$ and the *normalized entropy* $\text{Ent}(b)$ is defined by $\text{Ent}(f_b)$. The following theorem is due to Hironaka-Kin [16, Proposition 3.36] together with the observation by Kin-Takasawa [21, Section 4.1].

Theorem 1.1. *There is a sequence of pseudo-Anosov braids $z_n \in B_n$ such that $\text{Ent}(z_n) \neq 2 \log(2 + \sqrt{3})$, $M_{z_n} \simeq M_{\sigma_1^2 \sigma_2^{-1}}$ for each $n \geq 3$ and $\text{Ent}(z_n) \rightarrow 2 \log(2 + \sqrt{3})$ as $n \rightarrow \infty$.*

Here \simeq means they are homeomorphic to each other. The limit point $2 \log(2 + \sqrt{3})$ is equal to $\text{Ent}(\sigma_1^2 \sigma_2^{-1})$. By the lower bound (1.1), Theorem 1.1 implies that

$$\log \delta(\text{Mod}(\Sigma_{0,n})) \asymp \frac{1}{n}.$$

In particular, the hyperbolic fibered 3-manifold $M_{\sigma_1^2 \sigma_2^{-1}}$ admits an infinitely family of genus 0 fibers of fibrations over S^1 .

Let z_n be a pseudo-Anosov braid with d_n strands. We say that a sequence $\{z_n\}$ has a *small normalized entropy* if $d_n \asymp n$ and there is a constant $P > 0$ which does not depend on n such that $\text{Ent}(z_n) \leq P$. By (1.1) a sequence $\{z_n\}$ having a small normalized entropy means $\log(\lambda(z_n)) \asymp 1/n$. One of the aims in this paper is to give a construction of many sequences of pseudo-Anosov braids with small normalized entropies. The following result generalizes Theorem 1.1.

Theorem A. *Suppose that b is a pseudo-Anosov braid whose permutation has a fixed point. There is a sequence of pseudo-Anosov braids $\{z_n\}$ with small normalized entropy such that $\text{Ent}(z_n) \rightarrow \text{Ent}(b)$ as $n \rightarrow \infty$ and $M_{z_n} \simeq M_b$ for $n \geq 1$.*

The proof of Theorem A is constructive. In fact one can describe braids z_n explicitly. For a more general result see Theorems 5.1, 5.2. Let $\mathcal{C} \subset H_2(M_b, \partial M_b)$ be the fibered cone containing $[F_b]$. A theorem by Thurston [29] states that for each primitive integral class $a \in \mathcal{C}$ there is a connected fiber F_a with the pseudo-Anosov monodromy $\phi_a : F_a \rightarrow F_a$ of a fibration on the hyperbolic 3-manifold M_b over S^1 . The following theorem states a structure of \mathcal{C} .

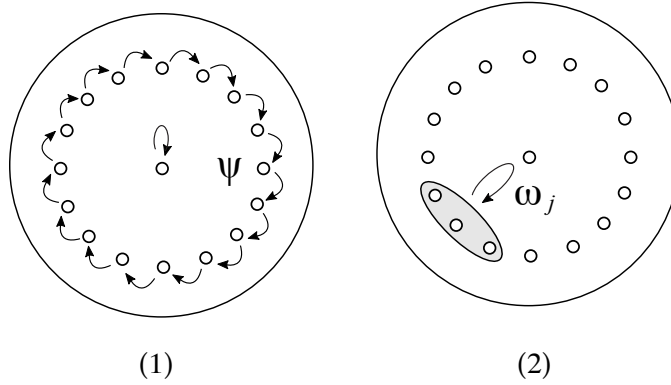

FIGURE 3. Dynamics of ψ and ω_j in Theorem B. (1) Periodic $\psi : F_a \rightarrow F_a$. (2) Reducible $\omega_j : F_a \rightarrow F_a$. Subsurface $h(S_0)$ is shaded.

Theorem B. *Suppose that b is a pseudo-Anosov braid whose permutation has a fixed point. Then there are a 2-dimensional subcone $\mathcal{C}_0 \subset \mathcal{C}$ and an integer $u \geq 1$ with the following properties.*

- (1) *The fiber F_a for each primitive integral class $a \in \mathcal{C}_0$ has genus 0.*
- (2) *The monodromy $\phi_a : F_a \rightarrow F_a$ for each primitive integral class $a \in \mathcal{C}_0$ is conjugate to*

$$(\omega_1\psi) \cdots (\omega_{u-1}\psi)(\omega_u\psi)\psi^{m-1} : F_a \rightarrow F_a,$$

where $m \geq 1$ depends on the class a , ψ is periodic and each ω_j is reducible. Moreover there are homeomorphisms $\widehat{\omega}_j : S_0 \rightarrow S_0$ on a surface S_0 for $j = 1, \dots, u$ determined by b and an embedding $h : S_0 \hookrightarrow F_a$ such that $h(S_0)$ is the support of each w_j and

$$w_j|_{h(S_0)} = h \circ \widehat{\omega}_j \circ h^{-1}.$$

Theorem B gives a constructive description of ϕ_a . Also it states that each $w_j : F_a \rightarrow F_a$ is reducible supported on a uniformly bounded subsurface $h(S_0) \subset F_a$. It turns out from the proof that the type of the periodic homeomorphism $\psi : F_a \rightarrow F_a$ does not depend on $a \in \mathcal{C}_0$ (Remark 3.3), see Figure 3(1). Theorem B reminds us of the symmetry conjecture in [23] by Farb-Leininger-Margalit.

Clearly the permutation of each pure braid has a fixed point. For any pseudo-Anosov braid b , a suitable power b^k becomes a pure braid and one can apply Theorems A, B for b^k .

We have a remark about Theorem A. While the existence of a sequence (F_n, ϕ_n) of fibers and monodromies in \mathcal{C} for which $\text{Ent}(\phi_n) \rightarrow \text{Ent}(b)$ is guaranteed by McMullen [25, Theorem 10.2], it does not say anything about the genera of fibers F_n . Theorem B has the extra (constructive) information that each fiber F_n along \mathcal{C}_0 is genus 0.

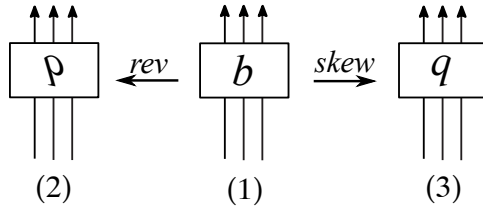

FIGURE 4. Illustration of braids (1) b , (2) $rev(b)$, (3) $skew(b)$.

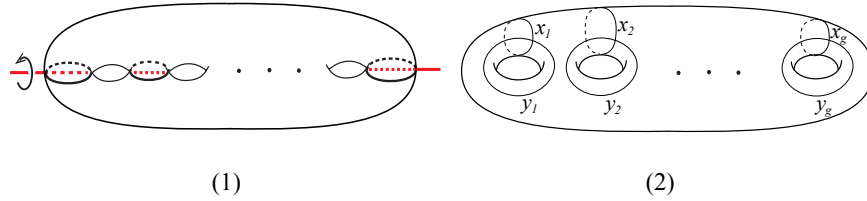

FIGURE 5. (1) $\mathcal{I} : \Sigma_g \rightarrow \Sigma_g$. (2) A basis $\{x_1, y_1, \dots, x_g, y_g\}$ of $H_1(\Sigma_g; \mathbb{Z}_2)$.

As an application we will determine asymptotic behaviors of the minimal dilatations of a subset of B_n consisting of braids with a symmetry. A braid $b \in B_n$ is *palindromic* if $rev(b) = b$, where $rev : B_n \rightarrow B_n$ is a map such that if w is a word of letters $\sigma_j^{\pm 1}$ representing b , then $rev(b)$ is the braid obtained from b reversing the order of letters in w . A braid $b \in B_n$ is *skew-palindromic* if $skew(b) = b$, where $skew(b) = \Delta rev(b) \Delta^{-1}$ and Δ is a half twist (Section 2.2). See Figure 4. We will prove that dilatations of palindromic braids have the following lower bound.

Theorem C. *If $b \in B_n$ is palindromic and pseudo-Anosov for $n \geq 3$, then*

$$\lambda(b) \geq \sqrt{2 + \sqrt{5}}.$$

In contrast with palindromic braids we have the following result.

Theorem D. *Let PA_n be the set of skew-palindromic elements in B_n . We have*

$$\log \delta(PA_n) \asymp \frac{1}{n}.$$

The *hyperelliptic mapping class group* $\mathcal{H}(\Sigma_g)$ is the subgroup of $\text{Mod}(\Sigma_g)$ consisting of elements with representative homeomorphisms that commute with some fixed hyperelliptic involution $\mathcal{I} : \Sigma_g \rightarrow \Sigma_g$ as in Figure 5(1). It is shown in [16] that $\log \delta(\mathcal{H}(\Sigma_g)) \asymp 1/g$. See also [7, 15, 19] for other subgroups of $\text{Mod}(\Sigma_g)$. As an application we will determine the asymptotic behavior of the minimal dilatations of the odd/even spin mapping class groups of genus g . To define these subgroups let $(\cdot, \cdot)_2$ be the mod-2 intersection form on $H_1(\Sigma_g; \mathbb{Z}_2)$. A map $q : H_1(\Sigma_g; \mathbb{Z}_2) \rightarrow \mathbb{Z}_2$ is a *quadratic form* if $q(v + w) = q(v) + q(w) + (v, w)_2$ for $v, w \in H_1(\Sigma_g; \mathbb{Z}_2)$. For a quadratic

form \mathfrak{q} , the *spin mapping class group* $\text{Mod}_g[\mathfrak{q}]$ is the subgroup of $\text{Mod}(\Sigma_g)$ consisting of elements ϕ such that $\mathfrak{q} \circ \phi_* = \mathfrak{q}$. To define the two quadratic forms \mathfrak{q}_0 and \mathfrak{q}_1 we choose a basis $\{x_1, y_1, \dots, x_g, y_g\}$ of $H_1(\Sigma_g; \mathbb{Z}_2)$ as in Figure 5(2). Let \mathfrak{q}_0 be the quadratic form such that $\mathfrak{q}_0(x_i) = \mathfrak{q}_0(y_i) = 0$ for $1 \leq i \leq g$. Let \mathfrak{q}_1 be the quadratic form such that $\mathfrak{q}_1(x_1) = \mathfrak{q}_1(y_1) = 1$ and $\mathfrak{q}_1(x_i) = \mathfrak{q}_1(y_i) = 0$ for $2 \leq i \leq g$. A result of Dye [5] tells us that $\text{Mod}_g[\mathfrak{q}]$ for any \mathfrak{q} is conjugate to either $\text{Mod}_g[\mathfrak{q}_0]$ or $\text{Mod}_g[\mathfrak{q}_1]$ in $\text{Mod}(\Sigma_g)$. We call $\text{Mod}_g[\mathfrak{q}_0]$ and $\text{Mod}_g[\mathfrak{q}_1]$ the *even spin* and *odd spin mapping class group* respectively. It is known that $\text{Mod}_g[\mathfrak{q}_1]$ attains the minimum index for a proper subgroup of $\text{Mod}(\Sigma_g)$ and $\text{Mod}_g[\mathfrak{q}_0]$ attains the secondary minimum, see Berrick-Gebhardt-Paris [2].

Theorem E. *We have*

- (1) $\log \delta(\text{Mod}_g[\mathfrak{q}_1] \cap \mathcal{H}(\Sigma_g)) \asymp \frac{1}{g}$ and
- (2) $\log \delta(\text{Mod}_g[\mathfrak{q}_0] \cap \mathcal{H}(\Sigma_g)) \asymp \frac{1}{g}$.

In particular $\log \delta(\text{Mod}_g[\mathfrak{q}]) \asymp 1/g$ for each quadratic form \mathfrak{q} .

Acknowledgments. We would like to thank Mitsuhiko Takasawa for helpful conversations and comments. The first author was supported by Grant-in-Aid for Scientific Research (C) (No. 16K05156), Japan Society for the Promotion of Science. The second author was supported by Grant-in-Aid for Scientific Research (C) (No. 18K03299), Japan Society for the Promotion of Science.

2. Preliminaries

2.1. Links. Let L be a link in the 3-sphere S^3 . Let $\mathcal{N}(L)$ denote a tubular neighborhood of L and let $\mathcal{E}(L)$ denote the exterior of L , i.e. $\mathcal{E}(L) = S^3 \setminus \text{int}(\mathcal{N}(L))$.

Oriented links L and L' in S^3 are *equivalent*, denoted by $L \sim L'$ if there is an orientation preserving homeomorphism $f : S^3 \rightarrow S^3$ such that $f(L) = L'$ with respect to the orientations of the links. Furthermore for components K_i of L and K'_i of L' with $i = 1, \dots, m$ if f satisfies $f(K_i) = K'_i$ for each i , then (L, K_1, \dots, K_m) and (L', K'_1, \dots, K'_m) are *equivalent* and we write

$$(L, K_1, \dots, K_m) \sim (L', K'_1, \dots, K'_m).$$

2.2. Braid groups B_n and spherical braid groups SB_n . Let us set

$$\delta_j = \sigma_1 \sigma_2 \cdots \sigma_{j-1} \quad \text{and} \quad \rho_j = \sigma_1 \sigma_2 \cdots \sigma_{j-2} \sigma_{j-1}^2.$$

The half twist Δ_j is given by

$$\Delta_j = \delta_j \delta_{j-1} \cdots \delta_2.$$

We often omit the subscript n in Δ_n , δ_n and ρ_n when they are precisely n -braids.

We put indices $1, 2, \dots, n$ from left to right on the bottoms of strands, and give an orientation of strands from the bottom to the top (Figure 1). The closure $\text{cl}(b)$ is oriented by the strands. We think of $\text{br}(b) = \text{cl}(b) \cup A$ as an oriented link in S^3 choosing an orientation of $A = A_b$ arbitrarily. (In Section 3 we assign an orientation of the braid axis for *i-monotonic braids*).

If two braids are conjugate to each other, then their braided links are equivalent. Morton proved that the converse holds if their axes are preserved.

Theorem 2.1 (Morton [26]). *If $(\text{br}(b), A_b)$ is equivalent to $(\text{br}(c), A_c)$ for braids $b, c \in B_n$, then b and c are conjugate in B_n .*

Let us turn to the spherical braid group SB_n with n strands. We also denote by σ_i , the element of SB_n as shown in Figure 1(1). The group SB_n is generated by $\sigma_1, \dots, \sigma_{n-1}$. For a braid $b \in B_n$ represented by a word of letters $\sigma_j^{\pm 1}$, let $S(b)$ denote the element in SB_n represented by the same word as b .

For a braid b in B_n or SB_n the *degree* of b means the number n of the strands, denoted by $d(b)$.

2.3. Mapping classes and mapping tori from braids. Let D_n be the n -punctured disk. Consider the mapping class group $\text{Mod}(D_n)$, the group of isotopy classes of orientation preserving self-homeomorphisms on D_n preserving the boundary ∂D of the disk setwise. We have a surjective homomorphism

$$\Gamma : B_n \rightarrow \text{Mod}(D_n)$$

which sends each generator σ_i to the right-handed half twist t_i between the i th and $(i + 1)$ st punctures. The kernel of Γ is an infinite cyclic group generated by the full twist Δ^2 .

Collapsing ∂D to a puncture in the sphere we have a homomorphism

$$c : \text{Mod}(D_n) \rightarrow \text{Mod}(\Sigma_{0,n+1}).$$

We say that $b \in B_n$ is *periodic* (resp. *reducible*, *pseudo-Anosov*) if $f_b := c(\Gamma(b))$ is of the corresponding Nielsen-Thurston type. The braids $\delta, \rho \in B_n$ are periodic since some power of each braid is the full twist: $\Delta^2 = \delta^n = \rho^{n-1} \in B_n$.

We also have a surjective homomorphism

$$\widehat{\Gamma} : SB_n \rightarrow \text{Mod}(\Sigma_{0,n})$$

sending each generator σ_i to the right-handed half twist t_i . We say that $\eta \in SB_n$ is *pseudo-Anosov* if $\widehat{\Gamma}(\eta) \in \text{Mod}(\Sigma_{0,n})$ is pseudo-Anosov. In this case $\lambda(\eta)$ is defined by the dilatation of $\widehat{\Gamma}(\eta)$.

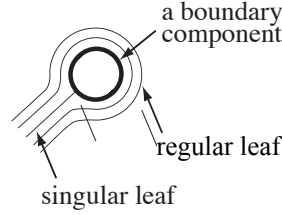

FIGURE 6. Stable foliation which is 1-pronged at a boundary component.

2.4. Stable foliations \mathcal{F}_b for pseudo-Anosov braids b . Recall the surjective homomorphism $\pi : B_n \rightarrow \mathcal{S}_n$. We write $\pi_b = \pi(b)$ for $b \in B_n$. Consider a pseudo-Anosov braid $b \in B_n$ with $\pi_b(i) = i$. Removing the i th strand $b(i)$ from b , we get a braid $b - b(i) \in B_{n-1}$. Taking its spherical element, we have $S(b - b(i)) \in SB_{n-1}$. Note that $b - b(i)$ and $S(b - b(i))$ are not necessarily pseudo-Anosov. A well-known criterion uses the stable foliation \mathcal{F}_b for the monodromy $\phi_b : F_b \rightarrow F_b$ of a fibration on $M_b \rightarrow S^1$ as we recall now. Such a fibration on M_b extends naturally to a fibration on the manifold obtained from M_b by Dehn filling a cusp along the boundary slope of the fiber F_b which lies on the torus $\partial\mathcal{N}(\text{cl}(b(i)))$. Also ϕ_b extends to the monodromy defined on F_b^\bullet of the extended fibration, where F_b^\bullet is obtained from F_b by filling in the boundary component of F_b which lies on $\partial\mathcal{N}(\text{cl}(b(i)))$ with a disk. Then $b - b(i)$ is the corresponding braid for the extended monodromy defined on F_b^\bullet . Suppose that \mathcal{F}_b is not 1-pronged at the boundary component in question. (See Figure 6 in the case where F_b is 1-pronged at a boundary component.) Then \mathcal{F}_b extends to the stable foliation for $b - b(i)$, and hence $b - b(i)$ is pseudo-Anosov with the same dilatation as b . Furthermore if \mathcal{F}_b is not 1-pronged at the boundary component of F_b which lies on $\partial\mathcal{N}(A)$, then $S(b - b(i))$ is still pseudo-Anosov with the same dilatation as b .

2.5. Thurston norm. Let M be a 3-manifold with boundary (possibly $\partial M = \emptyset$). If M is hyperbolic, i.e. the interior of M possess a complete hyperbolic structure of finite volume, then there is a norm $\|\cdot\|$ on $H_2(M, \partial M; \mathbb{R})$, now called the Thurston norm [29]. The norm $\|\cdot\|$ has the property such that for any integral class $a \in H_2(M, \partial M; \mathbb{R})$, $\|a\| = \min_S \{-\chi(S)\}$, where the minimum is taken over all oriented surface S embedded in M with $a = [S]$ and with no components of non-negative Euler characteristic. The surface S realizing this minimum is called a *norm-minimizing surface* of a .

Theorem 2.2 (Thurston [29]). *The norm $\|\cdot\|$ on $H_2(M, \partial M; \mathbb{R})$ has the following properties.*

- (1) *There are a set of maximal open cones $\mathcal{C}_1, \dots, \mathcal{C}_k$ in $H_2(M, \partial M; \mathbb{R})$ and a bijection between the set of isotopy classes of connected fibers of fibrations $M \rightarrow S^1$ and the set of primitive integral classes in the union $\mathcal{C}_1 \cup \dots \cup \mathcal{C}_k$.*

- (2) The restriction of $\|\cdot\|$ to \mathcal{C}_j is linear for each j .
- (3) If we let F_a be a fiber of a fibration $M \rightarrow S^1$ associated with a primitive integral class a in each \mathcal{C}_j , then $\|a\| = -\chi(F_a)$.

We call the open cones \mathcal{C}_j *fibered cones* and call integral classes in \mathcal{C}_j *fibered classes*.

Theorem 2.3 (Fried [11]). *For a fibered cone \mathcal{C} of a hyperbolic 3-manifold M , there is a continuous function $\text{ent} : \mathcal{C} \rightarrow \mathbb{R}$ with the following properties.*

- (1) For the monodromy $\phi_a : F_a \rightarrow F_a$ of a fibration $M \rightarrow S^1$ associated with a primitive integral class $a \in \mathcal{C}$, we have $\text{ent}(a) = \log(\lambda(\phi_a))$.
- (2) $\text{Ent} = \|\cdot\| \text{ent} : \mathcal{C} \rightarrow \mathbb{R}$ is a continuous function which becomes constant on each ray through the origin.
- (3) If a sequence $\{a_n\} \subset \mathcal{C}$ tends to a point $\neq 0$ in the boundary $\partial\mathcal{C}$ as n tends to ∞ , then $\text{ent}(a_n) \rightarrow \infty$. In particular $\text{Ent}(a_n) = \|a_n\| \text{ent}(a_n) \rightarrow \infty$.

We call $\text{ent}(a)$ and $\text{Ent}(a)$ the *entropy* and *normalized entropy* of the class $a \in \mathcal{C}$.

For a pseudo-Anosov element $\phi \in \text{Mod}(\Sigma)$ we consider the mapping torus M_ϕ . The vector field $\frac{\partial}{\partial t}$ on $\Sigma \times \mathbb{R}$ induces a flow ϕ^t on M_ϕ called the *suspension flow*.

Theorem 2.4 (Fried [10]). *Let ϕ be a pseudo-Anosov mapping class defined on Σ with stable and unstable foliations \mathcal{F}^s and \mathcal{F}^u . Let $\widehat{\mathcal{F}}^s$ and $\widehat{\mathcal{F}}^u$ denote the suspensions of \mathcal{F}^s and \mathcal{F}^u by ϕ . If \mathcal{C} is a fibered cone containing the fibered class $[\Sigma]$, then we can modify a norm-minimizing surface F_a associated with each primitive integral class $a \in \mathcal{C}$ by an isotopy on M_ϕ with the following properties.*

- (1) F_a is transverse to the suspension flow ϕ^t , and the first return map $\phi_a : F_a \rightarrow F_a$ is precisely the pseudo-Anosov monodromy of the fibration on $M_\phi \rightarrow S^1$ associated with a . Moreover F_a is unique up to isotopy along flow lines.
- (2) The stable and unstable foliations for ϕ_a are given by $\widehat{\mathcal{F}}^s \cap F_a$ and $\widehat{\mathcal{F}}^u \cap F_a$.

2.6. Disk twist. Let L be a link in S^3 . Suppose an unknot K is a component of L . Then the exterior $\mathcal{E}(K)$ (resp. $\partial\mathcal{E}(K)$) is a solid torus (resp. torus). We take a disk D bounded by the longitude of a tubular neighborhood $\mathcal{N}(K)$ of K . We define a mapping class T_D defined on $\mathcal{E}(K)$ as follows. We cut $\mathcal{E}(K)$ along D . We have resulting two sides obtained from D , and reglue two sides by twisting either of the sides 360 degrees so that the mapping class defined on $\partial\mathcal{E}(K)$ is the right-handed Dehn twist about ∂D . Such a mapping class on $\mathcal{E}(K)$ is called the *disk twist about D* . For simplicity we also call a self-homeomorphism representing the mapping class T_D the *disk twist about D* , and denote it by the same notation

$$T_D : \mathcal{E}(K) \rightarrow \mathcal{E}(K).$$

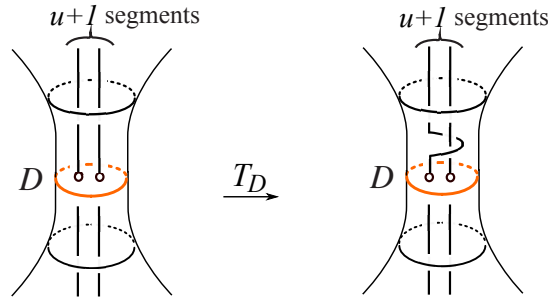

FIGURE 7. Disk twist T_D .

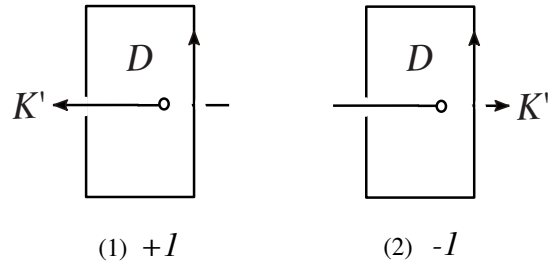

FIGURE 8. Sign of the point of intersection: $+1$ in (1) and -1 in (2).

Clearly T_D equals the identity map outside a neighborhood of D in $\mathcal{E}(K)$. We observe that if $u + 1$ segments of $L - K$ pass through D for $u \geq 1$, then $T_D(L - K)$ is obtained from $L - K$ by adding the full twist near D . In the case $u = 1$, see Figure 7. We may assume that T_D fixes one of these segments, since any point in D becomes the center of the twisting about D .

For any integer ℓ , consider a homeomorphism

$$T_D^\ell : \mathcal{E}(K) \rightarrow \mathcal{E}(K).$$

Observe that T_D^ℓ converts L into a link $K \cup T_D^\ell(L - K)$ such that $S^3 \setminus L$ is homeomorphic to $S^3 \setminus (K \cup T_D^\ell(L - K))$. Then T_D^ℓ induces a homeomorphism between the exteriors of links

$$h_{D,\ell} : \mathcal{E}(L) \rightarrow \mathcal{E}(K \cup T_D^\ell(L - K)). \tag{2.1}$$

We use the homeomorphism in (2.1) in later section.

3. i -increasing braids and Theorem 3.2

Definitions of i -increasing braids, signs and intersection numbers.

Let L be an oriented link in S^3 with a trivial component K . We take an oriented disk D bounded by the longitude of $\mathcal{N}(K)$ so that the orientation of D agrees with the orientation of K . For each component K' of $L - K$ such that D and K' intersect transversally with $D \cap K' \neq \emptyset$, we assign each point of intersection $+1$ or -1 as shown in Figure 8.

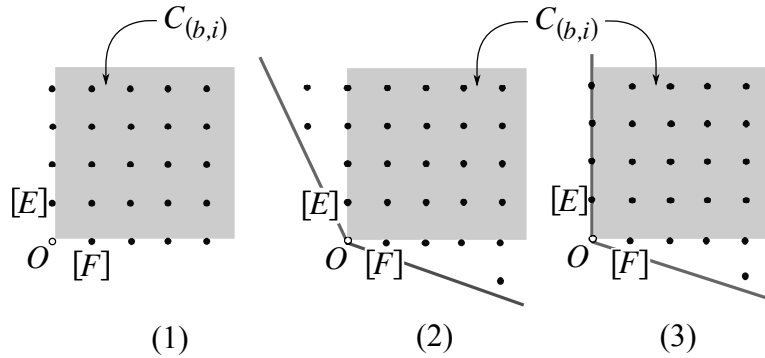

FIGURE 9. $F := F_b$ and $E := E_{(b,i)}$. (1) Subcone $C_{(b,i)}$. (2)(3) Possible shapes of $C \cap \{x[F] + y[E] \mid x, y \in \mathbb{R}\}$. In case (2), $[E] \in C$. In case (3), $[E] \notin C$.

Let b be a braid with $\pi_b(i) = i$. We consider an oriented disk $D = D_{(b,i)}$ bounded by the longitude ℓ_i of $\mathcal{N}(\text{cl}(b(i)))$. Such a disk D is unique up to isotopy on $\mathcal{E}(\text{cl}(b(i)))$. We say that a braid $b \in B_n$ with $\pi_b(i) = i$ is *i-increasing* (resp. *i-decreasing*) if there is a disk $D = D_{(b,i)}$ as above with the following conditions.

- (D1) There is at least one component K' of $\text{cl}(b - b(i))$ such that $D \cap K' \neq \emptyset$.
- (D2) Each component of $\text{cl}(b - b(i))$ and D intersect with each other transversally, and every point of intersection has the sign $+1$ (resp. -1).

We set $\epsilon(b, i) = 1$ (resp. $\epsilon(b, i) = -1$), and call it the *sign* of the pair (b, i) . We also call D the *associated disk* of the pair (b, i) . We say that b is *i-monotonic* if b is *i-increasing* or *i-decreasing*. Then we set

$$I(b, i) = D \cap \text{cl}(b - b(i))$$

and let $u(b, i) \geq 1$ be the cardinality of $I(b, i)$. We call $u(b, i)$ the *intersection number* of the pair (b, i) . If the pair (b, i) is specified, then we simply denote $\epsilon(b, i)$ and $u(b, i)$ by ϵ and u respectively. For example $\sigma_1^2 \sigma_2^{-1}$ is 1-increasing with $u(\sigma_1^2 \sigma_2^{-1}, 1) = 1$.

A braid b is *positive* if b is represented by a word in letters σ_j , but not σ_j^{-1} . A braid b is *irreducible* if the Nielsen-Thurston type of b is not reducible.

Lemma 3.1. *Let b be a positive braid with $\pi_b(i) = i$. Then b is i-increasing if b is irreducible.*

Proof. Suppose that a positive braid b with $\pi_b(i) = i$ is irreducible. Since b is positive, there is a disk $D = D_{(b,i)}$ with the condition (D2). Assume that D fails in (D1). Let ∂D_n be the boundary of the disk D_n containing n punctures. Consider a neighborhood of $\partial D_n \cup (D_n \cap D)$ in D_n which is an annulus. One of the boundary components of this annulus is an essential

simple closed curve in D_n preserved by $\Gamma(b) \in \text{Mod}(D_n)$. This means that b is reducible, a contradiction. Thus D satisfies (D1), and b is i -increasing. \square

Orientation of the axis A . Let b be i -monotonic with $\epsilon(b, i) = \epsilon$ and $u(b, i) = u$. Consider the braided link $\text{br}(b) = \text{cl}(b) \cup A$. The associated disk D has a unique point of intersection with A , and the cardinality of $I(b, i) \cup (D \cap A)$ is $u(b, i) + 1$. To deal with $\text{br}(b) = \text{cl}(b) \cup A$ as an oriented link, we consider an orientation of $\text{cl}(b)$ as we described before, and assign an orientation of A so that the sign of the intersection between D and A coincides with $\epsilon(b, i)$. See Figure 2(2).

Recall that $M_b = \mathcal{E}(\text{br}(b))$ is the exterior of $\text{br}(b)$ which is a surface bundle over S^1 . We consider an orientation of the F -surface F_b which agrees with the orientation of A .

E -surface. We now define an oriented surface $E_{(b,i)}$ of genus 0 embedded in M_b . Consider small $u(b, i) + 1$ disks in the oriented disk $D = D_{(b,i)}$ whose centers are points of $I(b, i) \cup (D \cap A)$. Then $E_{(b,i)}$ is a sphere with $u(b, i) + 2$ boundary components obtained from D by removing the interiors of those small disks. We choose the orientation of $E_{(b,i)}$ so that it agrees with the orientation of D . We call $E_{(b,i)}$ the E -surface for b . For example, the 1-increasing braid $\sigma_1^2 \sigma_2^{-1}$ has the E -surface $E_{(\sigma_1^2 \sigma_2^{-1}, 1)}$ homeomorphic to a 3-holed sphere.

Subcone $C_{(b,i)}$. Consider the 2-dimensional subcone of $H_2(M_b, \partial M_b; \mathbb{R})$ spanned by $[F_b]$ and $[E_{(b,i)}]$ (Figure 9):

$$C_{(b,i)} = \{x[F_b] + y[E_{(b,i)}] \mid x > 0, y > 0\}.$$

Let $\overline{C_{(b,i)}}$ denote the closure of $C_{(b,i)}$. We write $(x, y) = x[F_b] + y[E_{(b,i)}]$. We prove the following theorem in Section 4.

Theorem 3.2. *For a pseudo-Anosov, i -increasing braid b with $u(b, i) = u$, let \mathcal{C} be the fibered cone containing $[F_b]$. We have the following.*

- (1) $C_{(b,i)} \subset \mathcal{C}$.
- (2) The fiber $F_{(x,y)}$ for each primitive integral class $(x, y) \in C_{(b,i)}$ has genus 0.
- (3) The monodromy $\phi_{(x,y)} : F_{(x,y)} \rightarrow F_{(x,y)}$ for each primitive integral class $(x, y) \in C_{(b,i)}$ is conjugate to

$$(\omega_1 \psi) \cdots (\omega_{u-1} \psi) (\omega_u \psi) \psi^{m-1} : F_{(x,y)} \rightarrow F_{(x,y)},$$

where $m \geq 1$ depends on (x, y) , ψ is periodic and each ω_j is reducible. Moreover there are homeomorphisms $\widehat{w}_j : S_0 \rightarrow S_0$ for $j = 1, \dots, u$ on a surface S_0 determined by b and an embedding $h : S_0 \hookrightarrow F_{(x,y)}$ such that the subsurface $h(S_0)$ of $F_{(x,y)}$ is the support of each w_j and

$$w_j|_{h(S_0)} = h \circ \widehat{w}_j \circ h^{-1}.$$

The conclusion of Theorem 3.2 holds for i -decreasing braids as well. We now claim that Theorem 3.2 implies Theorem B.

Proof of Theorem B. Suppose that Theorem 3.2 holds. Let $b \in B_n$ be a pseudo-Anosov braid such that $\pi_b(i) = i$. We consider the braid $b\Delta^{2k} \in B_n$ for $k \geq 1$. The full twist Δ^2 is an element in the center $Z(B_n)$ and $\Delta^2 = \sigma_j P_j$ holds for each $1 \leq j \leq n - 1$, where P_j is positive. Such properties imply that $b\Delta^{2k}$ is positive for k large. We fix such large k . Since $\Gamma(b) = \Gamma(b\Delta^{2k})$ in $\text{Mod}(D_n)$, the braid $b\Delta^{2k}$ is certainly pseudo-Anosov. Hence it is i -increasing by Lemma 3.1. One can apply Theorem 3.2 for this braid, and obtains the subcone $C_{(b\Delta^{2k}, i)}$. Consider the k th power of the disk twist about the disk D_A bounded by the longitude of $\mathcal{N}(A)$:

$$T_{D_A}^k : \mathcal{E}(A) \rightarrow \mathcal{E}(A).$$

Since $A \cup T_{D_A}^k(\text{cl}(b)) = A \cup \text{cl}(b\Delta^{2k}) = \text{br}(b\Delta^{2k})$, we have $S^3 \setminus \text{br}(b) \simeq S^3 \setminus \text{br}(b\Delta^{2k})$. Let us set

$$f_k := h_{D_A, k} : M_b \rightarrow M_{b\Delta^{2k}},$$

where $h_{D_A, k}$ is the homeomorphism in (2.1). The isomorphism

$$f_{k*} : H_2(M_b, \partial M_b) \rightarrow H_2(M_{b\Delta^{2k}}, \partial M_{b\Delta^{2k}})$$

sends $[F_b]$ to $[F_{b\Delta^{2k}}]$. (Here we note that the above k is suppose to be large, but the homeomorphism f_k makes sense for all integer k .) The pullback of the subcone $C_{(b\Delta^{2k}, i)}$ into $H_2(M_b, \partial M_b)$ is a desired subcone contained in \mathcal{C} . □

Remark 3.3. *If $F_{(x,y)}$ is a $(d+1)$ -holed sphere, then the periodic homeomorphism $\psi : F_{(x,y)} \rightarrow F_{(x,y)}$ in Theorem 3.2 is determined by the periodic braid $\rho = \sigma_1 \sigma_2 \dots \sigma_{d-2} \sigma_{d-1}^2 \in B_d$. See the proof of Theorem 3.2(3) in Section 4.3.*

4. Proof of Theorem 3.2

We fix integers $n \geq 3$ and $1 \leq i \leq n$. Throughout Section 4, we assume that $b \in B_n$ is pseudo-Anosov and i -increasing with $u(b, i) = u$. We now choose an associated disk about the pair (b, i) suitably. Let \mathbb{D} denote the unit disk with the center $(0, 0)$ in the plane \mathbb{R}^2 . Let $J = (-1, 1) \times \{0\} \subset \mathbb{D}$ be the interval and let $A_0 = (-2, 0)$ be a point in \mathbb{R}^2 . We denote by \mathbb{D}_n , the disk \mathbb{D} with equally spaced n points in J . Let us denote these n points by A_1, \dots, A_n from left to right. We take a point $Q_i \neq A_i \in J$ between A_{i-1} and A_i so that the Euclidean distance $d(Q_i, A_i)$ is sufficiently small (e.g. $d(Q_i, A_i) < \frac{1}{n+1}$). Let r_i denote the closed interval in $[-2, 1] \times \{0\}$ with endpoints A_0 and Q_i . (Figure 10(1).) We regard b as a braid contained in the cylinder $\mathbb{D} \times [0, 1] \subset \mathbb{R}^3$ and b is based at n points $A_1 \times \{0\}, \dots, A_n \times \{0\}$. Since $\pi_b(i) = i$, one can take a representative of b such that $b(i)$ is an interval in the cylinder:

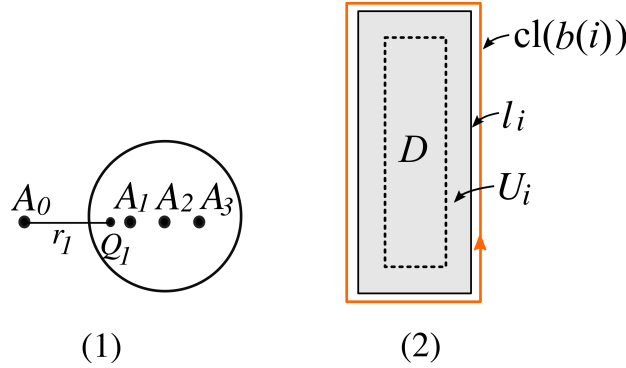

FIGURE 10. (1) $A_0, \dots, A_n, Q_i, r_i$ when $n = 3, i = 1$. (2) $\partial D = \ell_i$ is a union of four segments. U_i is an annulus in the figure.

$$\diamond 1. b(i) = \bigcup_{0 \leq t \leq 1} A_i \times \{t\}.$$

Furthermore we may assume that $\partial D (= \ell_i)$ of an associated disk D of (b, i) is a union of the following four segments as a set (Figure 10):

$$\diamond 2. \left(\bigcup_{-1 \leq t \leq 2} A_0 \times \{t\} \right) \cup (r_i \times \{-1\}) \cup \left(\bigcup_{-1 \leq t \leq 2} Q_i \times \{t\} \right) \cup (r_i \times \{2\}).$$

Preserving $\diamond 1, 2$ we may further assume the following (Figures 10(2), 11(1)):

$$\diamond 3. \text{ For a regular neighborhood } U_i \text{ of } \ell_i \text{ in } D, \text{ we have } I(b, i) \subset U_i.$$

This is because every point $x \in D \cap K'$, where K' is a component of $\text{cl}(b - b(i))$, one can slide x along K' so that the resulting point on K' is in U_i . Said differently, preserving ∂D pointwise, we can modify a small neighborhood of D near K' so that the resulting associated disk satisfies $\diamond 3$.

Under the conditions $\diamond 1, 2, 3$ we have the following. For each $x \in D \cap K' \subset U_i$, there is a segment $h' \subset K'$ through x such that h' passes over $b(i)$ since b is i -increasing. See Figure 11(1). Such a local picture of $\text{cl}(b)$ is used in the the next section. Hereafter we assume that associated disks possess conditions $\diamond 1, 2, 3$.

4.1. Proof of Theorem 3.2(1). Let s be the open segment (1-dimensional simplex) in $H_2(M_b, \partial M_b; \mathbb{R})$ with the endpoints $\frac{n-1}{u}[E_{(b,i)}] = (0, \frac{n-1}{u})$ and $[F_b] = (1, 0)$:

$$s = \{(x, y) \in C_{(b,i)} \mid y = -\frac{n-1}{u}x + \frac{n-1}{u}, 0 < x < 1\}. \tag{4.1}$$

The ray of each point in $C_{(b,i)}$ through the origin intersects with s . Thus for the proof of (1), it suffices to prove that $s \subset \mathcal{C}$.

We now introduce a sequence of braided links $\{\text{br}(b_p)\}_{p=1}^\infty$ from an i -increasing braid $b \in B_n$ such that $M_{b_p} \simeq M_b$ for each $p \geq 1$. (We use the

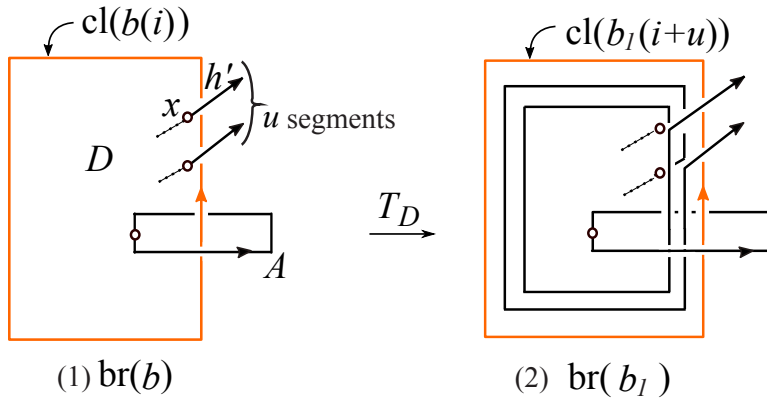

FIGURE 11. Case: b is i -increasing. (1) Associated disk D with conditions $\diamond 1, 2, 3$. (2) $\text{br}(b_l)$. Circles \circ indicate points of intersection between D and components of $\text{br}(b - b(i))$. See also Figure 12.

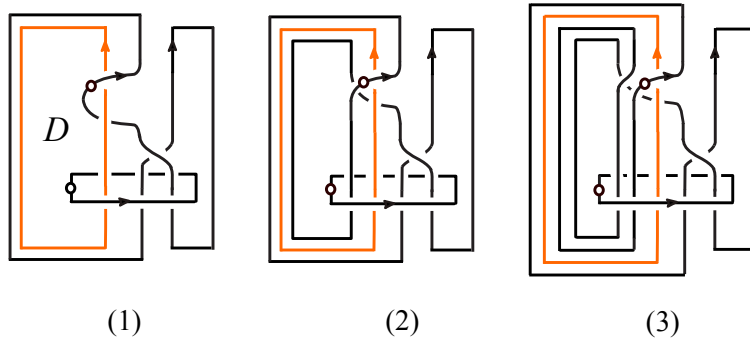

FIGURE 12. Braided links for (1) 1-increasing $\sigma_1^2 \sigma_2^{-1}$, (2) 2-increasing $(\sigma_1^2 \sigma_2^{-1})_1$ and (3) 3-increasing $(\sigma_1^2 \sigma_2^{-1})_2$.

1-increasing braid $\sigma_1^2 \sigma_2^{-1} \in B_3$ to illustrate the idea.) Let D be an associated disk of the pair (b, i) . We take a disk twist

$$T_D : \mathcal{E}(\text{cl}(b(i))) \rightarrow \mathcal{E}(\text{cl}(b(i)))$$

so that the point of intersection $D \cap A$ becomes the center of the twisting about D , i.e. $T_D(D \cap A) = D \cap A$. We may assume that $T_D(A) = A$ as a set. Figure 11 illustrates the image of the segment h' under T_D . The condition $\diamond 3$ ensures that T_D equals the identity map outside a neighborhood of U_i in $\mathcal{E}(\text{cl}(b(i)))$. Then by $\diamond 1, 2$, it follows that

$$T_D(\text{br}(b - b(i))) \cup \text{cl}(b(i))$$

is a braided link of some $(i + u)$ -increasing braid with $(n + u)$ strands. We define $b_1 \in B_{n+u}$ to be such a braid. The trivial knot $T_D(A)(= A)$ becomes

a braid axis of b_1 . By definition of the disk twist, we have $M_{b_1} \simeq M_b$. See Figure 12 for $\text{br}((\sigma_1^2 \sigma_2^{-1})_1)$.

As discussed below, there is some ambiguity in defining b_1 . As we will see, the ambiguity is irrelevant for the study of pseudo-Anosov monodromies defined on fibers of fibrations on the mapping torus. Suppose that both D and D' are the associated disks of the pair (b, i) with conditions $\diamond 1, 2, 3$. We consider the disk twists T_D and $T_{D'}$ with the above condition, i.e. both $D \cap A$ and $D' \cap A$ become the center of the twisting about D and D' respectively. Observe that the resulting two links obtained from D and D' are equivalent:

$$T_D(\text{br}(b - b(i))) \cup \text{cl}(b(i)) \sim T_{D'}(\text{br}(b - b(i))) \cup \text{cl}(b(i)).$$

They are braided links, say $\text{br}(b_1)$ and $\text{br}(b'_1)$ of some braids $b_1, b'_1 \in B_{n+u}$ respectively with the same axis $T_D(A) = A = T_{D'}(A)$. This means that a more stronger claim holds:

$$(\text{br}(b_1), A) \sim (\text{br}(b'_1), A).$$

Thus b_1 and b'_1 are conjugate in B_{n+u} by Theorem 2.1. In particular both b_1 and b'_1 are pseudo-Anosov (since the initial braid b is pseudo-Anosov and M_b is hyperbolic) and they have the same dilatation.

To define b_p for $p \geq 1$, we consider the p th power

$$T_D^p : \mathcal{E}(\text{cl}(b(i))) \rightarrow \mathcal{E}(\text{cl}(b(i)))$$

using the above T_D . As in the case of $p = 1$,

$$T_D^p(\text{br}(b - b(i))) \cup \text{cl}(b(i))$$

is a braided link of some $(i + pu)$ -increasing braid with $(n + pu)$ strands. We define $b_p \in B_{n+pu}$ to be such a braid. Then $M_{b_p} \simeq M_b$. As in the case of $p = 1$, such a braid b_p is well-defined up to conjugate. We say that b_p is obtained from b by the disk twist. Clearly $u(b_p, i + pu) = u(b, i)$ for $p \geq 1$. See Figure 12.

Let us set

$$g_p := h_{D,p} : M_b \rightarrow M_{b_p},$$

where $h_{D,p}$ is the homeomorphism in (2.1). We consider the isomorphism

$$g_{p*} : H_2(M_b, \partial M_b) \rightarrow H_2(M_{b_p}, \partial M_{b_p}).$$

Lemma 4.1. *For each integer $p \geq 1$, g_{p*} sends $(0, 1) \in \overline{C_{(b,i)}}$ to $(0, 1) \in \overline{C_{(b_p, i+pu)}}$, and sends $(1, p) \in \overline{C_{(b,i)}}$ to $(1, 0) \in \overline{C_{(b_p, i+pu)}}$. In particular for integers $x, y \geq 1$ with $y = xp + r$ for $0 \leq r < p$, g_{p*} sends $(x, y) \in \overline{C_{(b,i)}}$ to $(x, r) \in \overline{C_{(b_p, i+pu)}}$.*

Proof. We consider the oriented sum $F_{(x,y)} := xF_b + yE_{(b,i)}$. This is an oriented surface embedded in M_b , and is obtained from the cut and past construction of parallel x copies of F_b and parallel y copies of $E_{(b,i)}$. The orientation of $F_{(x,y)}$ agrees with those of F_b and $E_{(b,i)}$. We have $[F_{(x,y)}] = (x, y) \in C_{(b,i)}$. Then g_p sends $E_{(b,i)}$ to $E_{(b_p, i+pu)}$, and sends $F_{(1,p)}$ to F_{b_p} .

Thus g_{p*} sends $(0, 1)$ to $(0, 1)$, and sends $(1, p)$ to $(1, 0)$. This completes the proof. \square

By the proof of Lemma 4.1, g_1 sends $F_{(1,1)} = F_b + E_{(b,i)}$ to the fiber F_{b_1} of a fibration on M_b associated with $(1, 1) \in C_{(b,i)}$. Since the fibers $F_{(1,1)}$ and F_b are norm-minimizing, $E_{(b,i)}$ is also norm-minimizing.

Proof of Theorem 3.2(1). We have $\|[F_b]\| = n - 1$ and $\|[F_{b_p}]\| = n + pu - 1$ since F_b and F_{b_p} are fibers, and $\|[E_{(b,i)}]\| = u$ since $E_{(b,i)}$ is norm-minimizing. By Lemma 4.1, $[F_{b_p}] = (1, p) \in C_{(b,i)}$. Consider the rational class

$$c_p := \frac{n - 1}{n + pu - 1} [F_{b_p}] = \left(\frac{n - 1}{n + pu - 1}, \frac{p(n - 1)}{n + pu - 1} \right).$$

The classes c_p that are all projectively fibered, and they lie on the 1-dimensional linear simplex s given by (4.1). Note that the closure of s contains $[F_b]$. Moreover, the Thurston norm of all c_p equals that of $[F_b]$ (and it is $n - 1$). This is only possible if the simplex s is projectively contained in a single fibered face. The corresponding fibered cone has to contain $[F_b]$ from the above discussion, and hence it is \mathcal{C} . Thus $s \subset \mathcal{C}$. This completes the proof. \square

Remark 4.2. *From the proof of Theorem 3.2(1), one sees the following: If $[E_{(b,i)}] \in \overline{C_{(b,i)}}$ is a fibered class, then $[E_{(b,i)}] \in \mathcal{C}$. Otherwise $[E_{(b,i)}] \in \partial\mathcal{C}$. See Figure 9(2)(3).*

4.2. Proof of Theorem 3.2(2). We start with a simple observation: $\Delta^2 \in B_n$ is j -increasing for each $1 \leq j \leq n$, and $u(\Delta^2, j) = n - 1$ holds. The following lemma is immediate.

Lemma 4.3. *If $b \in B_n$ is i -increasing, then $b\Delta^2 \in B_n$ is i -increasing with $u(b\Delta^2, i) = u(b, i) + n - 1$.*

We explain the idea of Theorem 3.2(2). Let D be the associated disk of the pair (b, i) . We have two types of the disk twist. One is $T_{D_A}^k : \mathcal{E}(A) \rightarrow \mathcal{E}(A)$ which appears in the proof of Theorem B in Section 3 and the other is $T_D^p : \mathcal{E}(\text{cl}(b(i))) \rightarrow \mathcal{E}(\text{cl}(b(i)))$. If k and p are positive, then we obtain the i -increasing $b\Delta^{2k}$ from the former type $T_{D_A}^k$, and another increasing braid b_p from the latter type T_D^p . Since both resulting braids are increasing, we can further apply two types of the disk twist for the resulting braid. This is a key of the proof. Choosing two types of the disk twist alternatively, we get a sequence of increasing and pseudo-Anosov braids (since the initial braid b is pseudo-Anosov). We shall see that the desired monodromies associated with primitive classes in $C_{(b,i)}$ are given by these braids.

Let p_1, \dots, p_j be integers such that $p_1 \geq 0$ and $p_2, \dots, p_j \geq 1$. Given an i -increasing braid $b \in B_n$ with $u(b, i) = u$, we define an integer $i[p_1, \dots, p_j] \geq 1$ and an $i[p_1, \dots, p_j]$ -increasing braid $b[p_1, \dots, p_j]$ inductively as follows.

- If $j = 1$ and $p_1 = 0$, then $i[0] = i$ and $b[0] = b$. If $j = 1$ and $p_1 = p \geq 1$, then $i[p] = i + pu$ and $b[p] = b_p$.
- If $j > 1$ is even, then

$$\begin{aligned} i[p_1, \dots, p_{j-1}, p_j] &= i[p_1, \dots, p_{j-1}], \\ b[p_1, \dots, p_{j-1}, p_j] &= (b[p_1, \dots, p_{j-1}])\Delta^{2p_j}. \end{aligned}$$

The right-hand side is $i[p_1, \dots, p_{j-1}]$ -increasing by Lemma 4.3.

- If $j > 1$ is odd, then

$$\begin{aligned} i[p_1, \dots, p_{j-1}, p_j] &= i[p_1, \dots, p_{j-1}] + p_j u(b[p_1, \dots, p_{j-1}], i[p_1, \dots, p_{j-1}]), \\ b[p_1, \dots, p_{j-1}, p_j] &= (b[p_1, \dots, p_{j-1}])_{p_j}. \end{aligned}$$

We say that $b[p_1, \dots, p_j]$ has length j .

Example 4.4.

- (1) $b[p] = b_p$ by definition.
- (2) Let $\beta = b\Delta^2$. Then $b[0, 1] = \beta$ and $b[0, 1, p] = \beta_p$.
- (3) We have $b[0, p] = b\Delta^{2p}$ and $b[0, p, 1] = (b\Delta^{2p})_1$, where $(b\Delta^{2p})_1$ is obtained from i -increasing $b\Delta^{2p}$ by the disk twist.

For each $k \geq 1$, let $f_k : M_b \rightarrow M_{b\Delta^{2k}}$ be the homeomorphism which in the proof of Theorem B. Consider the isomorphism $f_{k*} : H_2(M_b, \partial M_b) \rightarrow H_2(M_{b\Delta^{2k}}, \partial M_{b\Delta^{2k}})$. We have the following property.

Lemma 4.5. *For each integer $k \geq 1$, f_{k*} sends $(1, 0) \in \overline{C_{(b,i)}}$ to $(1, 0) \in \overline{C_{(b\Delta^{2k}, i)}}$, and sends $(k, 1) \in \overline{C_{(b,i)}}$ to $(0, 1) \in \overline{C_{(b\Delta^{2k}, i)}}$. In particular for integers $x, y \geq 1$ with $x = yk + r$ for $0 \leq r < k$, then f_{k*} sends $(x, y) \in \overline{C_{(b,i)}}$ to $(r, y) \in \overline{C_{(b\Delta^{2k}, i)}}$.*

Proof. The homeomorphism f_k sends F_b to $F_{b\Delta^{2k}}$, and sends $F_{(k,1)} = kF_b + E_{(b,i)}$ to $E_{(b\Delta^{2k}, i)}$. This implies that the claim holds. \square

Proof of Theorem 3.2(2). Let $(x, y) \in C_{(b,i)}$ be a primitive integral class. (Hence x, y are positive integers with $\gcd(x, y) = 1$.) We consider the continued fraction of y/x by the Euclidean algorithm

$$\frac{y}{x} = p_1 + \frac{1}{p_2 + \frac{1}{p_3 + \dots + \frac{1}{p_{j-1} + \frac{1}{p_j}}}}$$

with length j and $p_j \geq 2$ and $p_1 = 0$ if $0 < y < x$. There is another expression

$$\frac{y}{x} = p_1 + \frac{1}{p_2 + p_3 + \dots + p_{j-1} + (p_j - 1)} + \frac{1}{1}$$

with length $j + 1$. We choose one of the two expressions with odd length ℓ :

$$\frac{y}{x} = p_1 + \frac{1}{p_2 + \frac{1}{p_3 + \cdots + \frac{1}{p_{\ell-1} + \frac{1}{p_\ell}}}}$$

This encodes the fiber $F_{(x,y)}$ and its monodromy $\phi_{(x,y)}$. In fact Lemmas 4.1, 4.5 ensure that

$$(g_{p_\ell} f_{p_{\ell-1}} g_{p_{\ell-2}} \cdots f_{p_2} g_{p_1})_* : H_2(M_b, \partial M_b) \rightarrow H_2(M_{b[p_1, \dots, p_\ell]}, \partial M_{b[p_1, \dots, p_\ell]})$$

sends $(x, y) = [xF_b + yE_{(b,i)}]$ to $(1, 0)$ which is the integral class of the F -surface of $b[p_1, \dots, p_\ell]$. ($g_{p_1} = id : M_b \rightarrow M_b$ if $p_1 = 0$.) Thus $F_{(x,y)}$ has genus 0. Moreover this means that one can take $F_{b[p_1, \dots, p_\ell]}$ as a representative of $(x, y) \in C_{(b,i)}$ and the monodromy $\phi_{(x,y)} : F_{(x,y)} \rightarrow F_{(x,y)}$ is determined by $b[p_1, \dots, p_\ell]$. This completes the proof. \square

We denote by $b_{(x,y)}$ the braid $b[p_1, \dots, p_\ell]$ which determines $\phi_{(x,y)}$. Here is an example: If $(x, y) = (5, 14)$, then $\frac{14}{5} = 2 + \frac{1}{1 + \frac{1}{4}}$ and $\phi_{(5,14)}$ is determined by $b_{(5,14)} = b[2, 1, 4]$. If $(x, y) = (14, 5)$, then $\frac{5}{14} = 0 + \frac{1}{2 + \frac{1}{1 + \frac{1}{3 + \frac{1}{1}}}}$ and $\phi_{(14,5)}$ is determined by $b_{(14,5)} = b[0, 2, 1, 3, 1]$.

4.3. Proof of Theorem 3.2(3). We begin with the following lemma.

Lemma 4.6 (Standard form). *If $b \in B_n$ is i -increasing with $u(b, i) = u$, then b is conjugate to an n -increasing braid b' of the form*

$$b' = (w_1 \sigma_{n-1}^2) \cdots (w_u \sigma_{n-1}^2),$$

where each w_k is a word of $\sigma_1^{\pm 1}, \dots, \sigma_{n-2}^{\pm 1}$, but not $\sigma_{n-1}^{\pm 1}$, possibly $w_k = \emptyset$ for some k .

Figure 13(1) shows the form of b' in Lemma 4.6 in case $u = 2$.

Proof. We regard b as a braid in $\mathbb{D} \times [0, 1]$. By $\diamond 1$, $b(i)$ is an interval in $\mathbb{D} \times [0, 1]$. If $i = n$, then b is n -increasing and it is not hard to see that a representative of b is of the desired form in Lemma 4.6. Suppose that b is i -increasing for $1 \leq i < n$. We set $\sigma = \sigma_{n-1} \sigma_{n-2} \cdots \sigma_i$ if $1 \leq i < n - 1$ and $\sigma = \sigma_{n-1}$ if $i = n - 1$. We consider the n -braid $b' = \sigma b \sigma^{-1}$ which is n -increasing with $u(b', n) = u$. We pull $b'(n)$ tight in $\mathbb{D} \times [0, 1]$ and make it straight. Then a representative of b' is of the desired form. \square

Proof of Theorem 3.2(3). Since each i -increasing braid is conjugate to an n -increasing braid of a standard form in Lemma 4.6, we may assume that $b \in B_n$ is an n -increasing braid of the form $b = (w_1 \sigma_{n-1}^2) \cdots (w_u \sigma_{n-1}^2)$. Since $\rho \in B_n$ is the periodic braid such that $\rho = \sigma_1 \sigma_2 \cdots \sigma_{n-2} \sigma_{n-1}^2$ we have $\sigma_{n-1}^2 = (\sigma_1 \cdots \sigma_{n-2})^{-1} \rho$. Then b is expressed as follows.

$$b = (\nu_1 \rho) \cdots (\nu_u \rho),$$

where $\nu_i = w_i (\sigma_1 \cdots \sigma_{n-2})^{-1}$ is written by a word of $\sigma_1^{\pm 1}, \dots, \sigma_{n-2}^{\pm 1}$, but not $\sigma_{n-1}^{\pm 1}$. Each ν_j in b is a reducible braid and ρ in b is the periodic braid.

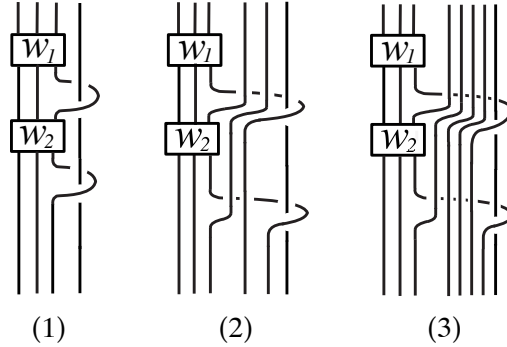

FIGURE 13. The figure illustrates how an initial braid b generates $\{b_p\}$. (1) $b = w_1\sigma_3^2w_2\sigma_3^2 = (\nu_1\rho)(\nu_2\rho) \in B_4$, where $\nu_j = w_j(\sigma_1\sigma_2)^{-1}$. (2) $b_1 = (\nu_1\rho)(\nu_2\rho) \in B_6$. (3) $b_2 = (\nu_1\rho)(\nu_2\rho) \in B_8$.

Let $\omega_j : F_b \rightarrow F_b$ denote a reducible representative whose mapping class is determined by ν_j , and let $\psi : F_b \rightarrow F_b$ denote a periodic representative whose mapping class determined by ρ . The monodromy ϕ_b defined on F_b is written by $\phi_b = (\omega_1\psi) \cdots (\omega_u\psi)$.

Recall that \mathbb{D}_{n-1} is the disk \mathbb{D} with marked points A_1, \dots, A_{n-1} . Let S_0 be an n -holed sphere obtained from \mathbb{D}_{n-1} by removing the interiors of small $(n - 1)$ disks with centers A_1, \dots, A_{n-1} . Each ν_j as an $(n - 1)$ -braid determines a homeomorphism $\hat{\omega}_j : S_0 \rightarrow S_0$. We may assume that $\hat{\omega}_j$ fixes one of the boundary components corresponding to $\partial\mathbb{D}$ pointwise. It is clear that we have an embedding $h : S_0 \hookrightarrow F_b$ such that each ω_j in ϕ_b is reducible supported on the subsurface $h(S_0)$ and the restriction of ω_j to $h(S_0)$ is given by $h \circ \hat{\omega}_j \circ h^{-1}$.

By the proof of Theorem 3.2(2), $\phi_{(x,y)} : F_{(x,y)} \rightarrow F_{(x,y)}$ associated with each primitive class $(x, y) \in C_{(b,i)}$ is determined by the braid of the form $b[p_1, \dots, p_\ell]$. We now prove by the induction on length ℓ that

$$b[p_1, \dots, p_\ell] = (\nu_1\rho) \cdots (\nu_{u-1}\rho)(\nu_u\rho)\rho^{m-1} = (\nu_1\rho) \cdots (\nu_{u-1}\rho)(\nu_u\rho^m)$$

for some $m \geq 1$ depending on (x, y) . Here each ν_j in $b[p_1, \dots, p_\ell]$ is a reducible braid which is an extension of ν_j in b and ρ is the periodic braid with the degree of $b[p_1, \dots, p_j]$. If this holds, then $\phi_{(x,y)}$ has a desired property as in Theorem 3.2(3). Suppose that $\ell = 1$. If $p_1 = 0$, then $b[0] = b$ and we are done. If $p_1 \geq 1$, then $b[p_1] = b_{p_1}$. Using the above expression of b we observe that b_{p_1} is written by

$$b_{p_1} = (\nu_1\rho) \cdots (\nu_u\rho) \in B_{n+p_1u}$$

(see Figure 13). We are done.

For $\ell \geq 2$, suppose that $b[p_1, \dots, p_{\ell-1}] = (\nu_1\rho_d) \cdots (\nu_{u-1}\rho_d)(\nu_u\rho_d^m)$ for some m , where d is the degree of $b[p_1, \dots, p_{\ell-1}]$. Consider $b[p_1, \dots, p_\ell]$ with

length ℓ . If ℓ is even, then by induction hypothesis

$$b[p_1, \dots, p_\ell] = (b[p_1, \dots, p_{\ell-1}])\Delta_d^{2p_\ell} = (\nu_1\rho_d) \cdots (\nu_{u-1}\rho_d)(\nu_u\rho_d^m)\Delta_d^{2p_\ell}.$$

Since $\Delta_d^2 = \rho_d^{d-1}$ we have $(\nu_u\rho_d^m)\Delta_d^{2p_\ell} = \nu_u\rho_d^{m+p_\ell(d-1)}$. Thus $b[p_1, \dots, p_\ell]$ has a desired expression and we are done. If ℓ is odd, then by induction hypothesis again

$$b[p_1, \dots, p_\ell] = (b[p_1, \dots, p_{\ell-1}])_{p_\ell} = ((\nu_1\rho_d) \cdots (\nu_{u-1}\rho_d)(\nu_u\rho_d^m))_{p_\ell}.$$

As in the case of $\ell = 1$, the braid in the right-hand side is expressed as

$$((\nu_1\rho_d) \cdots (\nu_{u-1}\rho_d)(\nu_u\rho_d^m))_{p_\ell} = (\nu_1\rho_\dagger) \cdots (\nu_{u-1}\rho_\dagger)(\nu_u\rho_\dagger^m),$$

where \dagger is the degree of $b[p_1, \dots, p_\ell]$. This completes the proof. □

5. Sequences of pseudo-Anosov braids with small normalized entropies

In this section we prove Theorem A. We begin with an observation. Let $\Omega \subset \{a \in \mathcal{C} \mid \|a\| = 1\}$ be a compact set in $H_2(M_b, \partial M_b; \mathbb{R})$ and let $\mathcal{C}_\Omega \subset \mathcal{C}$ denote the cone over Ω through the origin. By Theorem 2.3(2) there is a constant $P = P(\Omega) > 0$ depending on Ω such that $\text{Ent}(a) < P$ for any $a \in \mathcal{C}_\Omega$. This observation provides us many sequences of pseudo-Anosov braids with small normalized entropies from a single pseudo-Anosov braid b .

Theorem 5.1. *Suppose that b is a pseudo-Anosov braid whose permutation has a fixed point. We fix any $0 < \ell < \infty$. Let $\{(x_p, y_p)\}$ be a sequence of primitive integral classes in $\mathcal{C}_{(b,i)}$ such that $y_p/x_p < \ell$ and $\|(x_p, y_p)\| \asymp p$. Then the sequence of pseudo-Anosov braids $\{b_{(x_p, y_p)}\}$ has a small normalized entropy.*

Proof. If $\{(x_p, y_p)\}$ is the sequence under the assumption, then we have $d(b_{(x_p, y_p)}) \asymp \|(x_p, y_p)\| \asymp p$. (Recall that $d(\cdot)$ denotes the degree of the braid, i.e., the number of the strands.) Since $(1, 0) \in \mathcal{C}_{(b,i)} \subset \mathcal{C}$ and the slope of y_p/x_p is bounded by ℓ from above, the set of projective classes (x_p, y_p) is contained in some compact set in $\{a \in \mathcal{C} \mid \|a\| = 1\}$ (Figure 9). Thus there is a constant $P = P(\ell) > 1$ such that $\text{Ent}(b_{(x_p, y_p)}) < P$ for any p . This completes the proof. □

Let us discuss three sequences coming from Example 4.4. They are $\{b_p\}$, $\{\beta_p\}$ and $\{(b\Delta^{2p})_1\}$ varying p . It is not hard to see that $d(b_p)$, $d(\beta_p)$, $d((b\Delta^{2p})_1) \asymp p$.

Theorem 5.2. *For an i -increasing and pseudo-Anosov $b \in B_n$, we have the following on the sequences of pseudo-Anosov braids.*

- (1) $\{b_p\}$ has a small normalized entropy if and only if $[E_{(b,i)}]$ is a fibered class.

- (2) For $\beta = b\Delta^2 \in B_n$, $\{\beta_p\}$ has a small normalized entropy and $\text{Ent}(\beta_p) \rightarrow \text{Ent}((1, 1))$ as $p \rightarrow \infty$.
- (3) $\{(b\Delta^{2p})_1\}$ has a small normalized entropy and $\text{Ent}((b\Delta^{2p})_1) \rightarrow \text{Ent}(b)$ as $p \rightarrow \infty$.

Proof of Theorem 5.2. For $a = (x, y) \in \overline{C_{(b,i)}}$, let $\underline{a} = (x, y)$ denote its projective class. We have $[F_{b_p}] = (1, p) \rightarrow [E_{(b,i)}] = (0, 1)$ as $p \rightarrow \infty$. If $[E_{(b,i)}]$ is a fibered class, then $[E_{(b,i)}] \in \mathcal{C}$ by Remark 4.2 and $\text{Ent}(b_p) \rightarrow \text{Ent}([E_{(b,i)}])$ as $p \rightarrow \infty$ by Theorem 2.3(2). If $[E_{(b,i)}]$ is a non-fibered class, then $[E_{(b,i)}] \in \partial\mathcal{C}$ by Remark 4.2, and $\text{Ent}(b_p) \rightarrow \infty$ as $p \rightarrow \infty$ by Theorem 2.3(3). We finish the proof of (1). We turn to (2). Since $[F_{\beta_p}] = (p + 1, p) \in C_{(b,i)}$, its projective class goes to $(1, 1)$ as $p \rightarrow \infty$. Since $(1, 1) \in C_{(b,i)} \subset \mathcal{C}$ by Theorem 3.2(1), $\text{Ent}(\beta_p) \rightarrow \text{Ent}((1, 1))$ as $p \rightarrow \infty$ by Theorem 2.3(2). This completes the proof of (2). Finally we prove (3). The fibered class of F -surface of $(b\Delta^{2p})_1$ is given by $(p + 1, 1) \in C_{(b,i)}$. Its projective class goes to $[F_b] = (1, 0)$ as $p \rightarrow \infty$. Thus $\text{Ent}((b\Delta^{2p})_1) \rightarrow \text{Ent}(b)$ as $p \rightarrow \infty$. This completes the proof. \square

We use Theorem 5.2(1)(2) in Section 8. For an application using (3), see [19].

Proof of Theorem A. Suppose that $b \in B_n$ is pseudo-Anosov with $\pi_b(i) = i$. Let $\beta(k)$ denote $b\Delta^{2k} \in B_n$ for $k \geq 1$. Clearly $\beta(k)$ is pseudo-Anosov with the same dilatation as b (for any k) and $\beta(k)$ is positive for k large. We fix such large k . By Lemma 3.1 $\beta(k)$ is i -increasing. If we let $z_p = (\beta(k)\Delta^{2p})_1$, then $M_{z_p} \simeq M_{\beta(k)} \simeq M_b$ holds for $p \geq 1$. By Theorem 5.2(3), $\{z_p\}$ has a small normalized entropy and $\text{Ent}(z_p) \rightarrow \text{Ent}(\beta(k)) = \text{Ent}(b)$ as $p \rightarrow \infty$. \square

Let b_p^\bullet denote the braid obtained from $(i + pu)$ -increasing b_p by removing the strand of the index $i + pu$. Taking its spherical element we have $S(b_p^\bullet)$. A mild generalization of the sequence $\{b_p\}$ is the ones $\{b_p^\bullet\}$ and $\{S(b_p^\bullet)\}$ varying p . Although $b_p^\bullet, S(b_p^\bullet)$ may not be pseudo-Anosov, they are frequently pseudo-Anosov. To be more precise, we need to consider the number of prongs of singularities in the stable foliation \mathcal{F}_{b_p} for b_p as we explained in Section 2.3. This is the motivation of the study in Section 6.

6. Stable foliation for the monodromy

Let b be pseudo-Anosov and i -monotonic with the sign $\epsilon(b, i) = \epsilon$. For any primitive integral class $(x, y) \in C_{(b,i)}$, the oriented sum $F_{(x,y)} = xF_b + yE_{(b,i)}$ is connected. Let $\mathcal{T}_{(b,A)}$ and $\mathcal{T}_{(b,i)}$ denote the tori $\partial\mathcal{N}(A)$ and $\partial\mathcal{N}(\text{cl}(b(i)))$ respectively. Let us set

$$\partial_{(b,A)}F_{(x,y)} = \partial F_{(x,y)} \cap \mathcal{T}_{(b,A)} \quad \text{and} \quad \partial_{(b,i)}F_{(x,y)} = \partial F_{(x,y)} \cap \mathcal{T}_{(b,i)},$$

each of which is a single simple closed curve on the torus (since $\text{gcd}(x, y) = 1$). Recall that we chose the orientation of the axis for the i -monotonic b

$[c_A]$ has a non-zero first coordinate of the meridian and longitude basis for $\mathcal{T}_{(b,A)}$, i.e., we have $[c_A] = (k, \ell) \in \mathbb{Z}^2$ with $k \neq 0$, since the meridian for $\mathcal{T}_{(b,A)}$ corresponds to the flow direction. Similarly, $[c_i]$ has a non-zero second coordinate of the meridian and longitude basis for $\mathcal{T}_{(b,i)}$, that is we have $[c_i] = (k', \ell') \in \mathbb{Z}^2$ with $\ell' \neq 0$, since the longitude for $\mathcal{T}_{(b,i)}$ corresponds to the flow direction in this case.

Recall that given a braid $b \in B_n$, we denote by $S(b) \in SB_n$, the spherical n -braid with the same word as b . For an i -increasing braid b of pseudo-Anosov type, consider the braid $(b\Delta^{2p})_1 = b[0, p, 1]$ in Example 4.4(3). This is an $i[0, p, 1]$ -increasing braid. Then we have its spherical braid $S((b\Delta^{2p})_1)$. We now define other braids obtained from $(b\Delta^{2p})_1$. Let $(b\Delta^{2p})_1^\bullet$ denote the braid obtained from $(b\Delta^{2p})_1$ by removing the strand of the index $i[0, p, 1]$. Let $S((b\Delta^{2p})_1)$ and $S((b\Delta^{2p})_1^\bullet)$ be the spherical braids corresponding to $(b\Delta^{2p})_1$ and $(b\Delta^{2p})_1^\bullet$ respectively. Then we have the following result.

Lemma 6.3. *Suppose that b is an i -increasing braid of pseudo-Anosov type. For p large, the braid $(b\Delta^{2p})_1^\bullet$ and the spherical braids $S((b\Delta^{2p})_1)$, $S((b\Delta^{2p})_1^\bullet)$ are all pseudo-Anosov with the same dilatation as $(b\Delta^{2p})_1$.*

Before proving Lemma 6.3, we recall a formula of the geometric intersection number $i([c], [c'])$ between two homology classes of simple closed curves c, c' on a torus. Let (p, q) and (p', q') be primitive elements of \mathbb{Z}^2 which represent $[c]$ and $[c']$ respectively. Then

$$i([c], [c']) = |pq' - p'q|.$$

Proof of Lemma 6.3. The fibered class of F -surface of $(b\Delta^{2p})_1$ is $(p + 1, 1) \in C_{(b,i)}$. We have $[\partial_{(b,A)}F_{(p+1,1)}] = (-1, p + 1)$ and $[\partial_{(b,i)}F_{(p+1,1)}] = (-(p+1), 1)$, see (6.1). By Remark 6.2, one can write $[c_A] = (k, \ell)$ with $k \neq 0$ and $[c_i] = (k', \ell')$ with $\ell' \neq 0$. Then $i([c_A], [\partial_{(b,A)}F_{(p+1,1)}]) = |k(p + 1) + \ell|$ and $i([c_i], [\partial_{(b,i)}F_{(p+1,1)}]) = |k' + \ell'(p + 1)|$. Since $k \neq 0$ and $\ell' \neq 0$, these intersection numbers are increasing with respect to p and they are clearly greater than 1 when p is large. Then Lemma 6.1 says that when p is large, the stable foliation $\mathcal{F}_{(p+1,1)}$ for the monodromy $\phi_{(p+1,1)}$ is not 1-pronged at each component of $\partial_{(b,A)}F_{(p+1,1)} \cup \partial_{(b,i)}F_{(p+1,1)}$. By the discussion in Section 2.4, we are done. \square

7. Properties of F -surfaces and E -surfaces

The aim of this section is to study properties of E -, F -surfaces and to present the technique used in the last section.

Lemma 7.1. *For an i -increasing braid $b \in B_n$ with $u(b, i) = u$, we set $\beta = b\Delta^2 \in B_n$. Then there is an n -increasing braid $\gamma \in B_{n+u}$ such that*

$$(\text{br}(\beta), \text{cl}(\beta(i)), A_\beta) \sim (\text{br}(\gamma), A_\gamma, \text{cl}(\gamma(n))).$$

In particular $M_b \simeq M_\beta \simeq M_\gamma$ and $E_{(\beta,i)} = F_\gamma$, $F_\beta = E_{(\gamma,n)}$ up to isotopy in M_β . Moreover if b is pseudo-Anosov, then γ is also pseudo-Anosov.

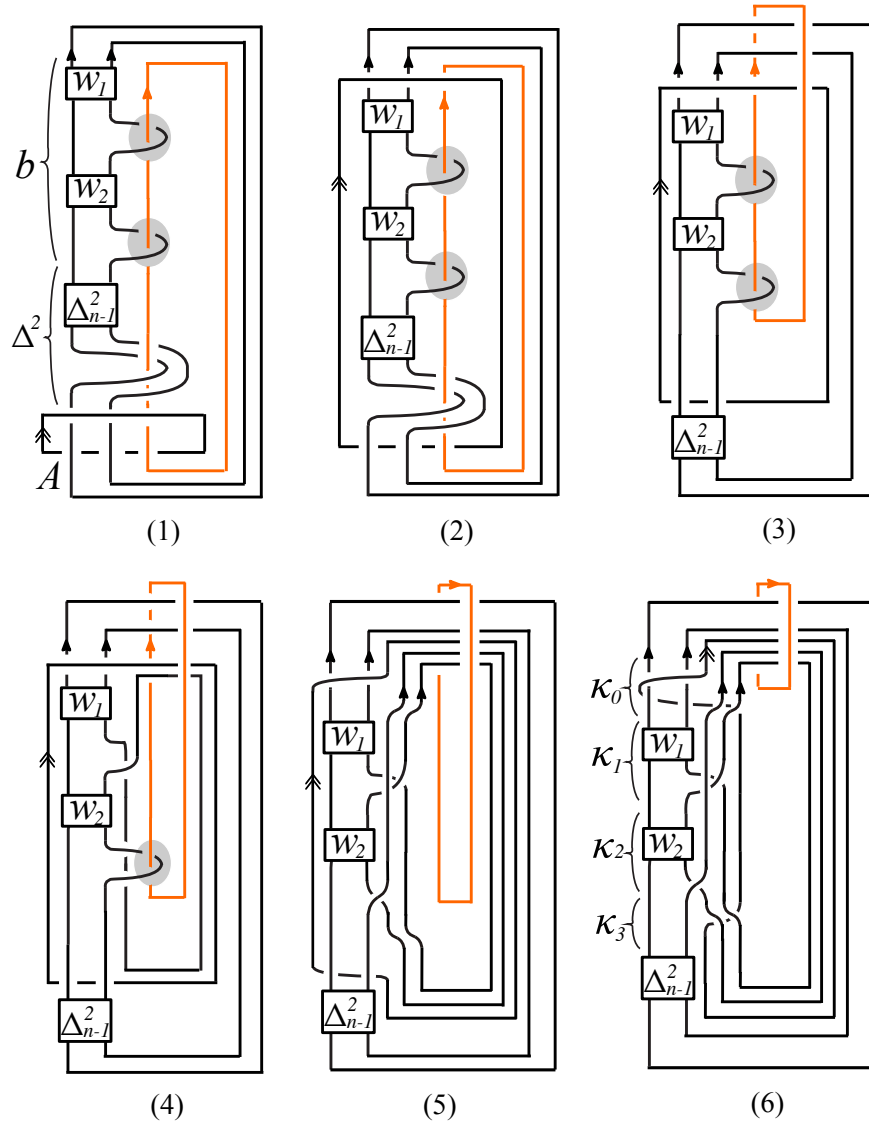

FIGURE 15. Demonstration of Lemma 7.1 when b is n -increasing with $u(b, n) = 2$. (1) $\text{br}(\beta)$ of $\beta = w_1 \sigma_{n-1}^2 w_2 \sigma_{n-1}^2 \Delta^2$. (5)(6) $\text{br}(\gamma)$ of $\gamma = \kappa_0 \kappa_1 \kappa_2 \kappa_3 \Delta_{n-1}^2$.

A similar claim holds for i -decreasing braids.

Proof. By Lemma 4.6 we may assume that $b \in B_n$ is an n -increasing braid of a standard form $b = (w_1 \sigma_{n-1}^2) \cdots (w_u \sigma_{n-1}^2)$ containing u subwords σ_{n-1}^2 . Using the identity

$$\Delta^2 = \Delta_{n-1}^2 \sigma_{n-1} \cdots \sigma_2 \sigma_1 \sigma_1 \sigma_2 \cdots \sigma_{n-1} \in B_n,$$

we have (Figure 15(1))

$$\text{br}(\beta) = \text{br}(b\Delta^2) = \text{br}(w_1\sigma_{n-1}^2 \cdots w_u\sigma_{n-1}^2\Delta_{n-1}^2\sigma_{n-1} \cdots \sigma_2\sigma_1\sigma_1\sigma_2 \cdots \sigma_{n-1}).$$

We first deform $\text{br}(\beta)$ into a link as in Figure 15(3). The same figure(1)(2)(3) tells us the process to get the desired link in (3). Then we perform the local moves in the shaded regions containing u subwords σ_{n-1}^2 in b so that the link in question is a union of the closure of some n -increasing braid $\gamma \in B_{n+u}$ and its braided axis, namely a braided link, see Figure 15(3)(4)(5). As a result,

$$(\text{br}(\beta), \text{cl}(\beta(n)), A_\beta) \sim (\text{br}(\gamma), A_\gamma, \text{cl}(\gamma(n))).$$

This expression says that $M_\beta \simeq M_\gamma$ and the E -, F -surfaces for β are equal to the F -, E -surfaces for γ . Since $M_b \simeq M_\beta$ we are done. \square

Here we introduce a simple representative of $\gamma \in B_{n+u}$ in Lemma 7.1. By the deformation as in (5)(6) of Figure 15, we can take the following representative of γ .

$$\begin{aligned} \gamma &= \kappa_0\kappa_1 \cdots \kappa_{u+1}\Delta_{n-1}^2, \text{ where} \\ \kappa_0 &= \sigma_{n-1}\sigma_{n-2} \cdots \sigma_1\sigma_1\sigma_2 \cdots \sigma_{n+u-1}, \\ \kappa_j &= w_j\sigma_{n-1}\sigma_n \cdots \sigma_{n+u-j-1}\sigma_{n+u-j-2}^{-1} \cdots \sigma_{n-1}^{-1} \quad \text{if } 1 \leq j \leq u-1, \\ \kappa_u &= w_u\sigma_{n-1}, \\ \kappa_{u+1} &= \sigma_n^{-1} \quad \text{if } u = 1, \\ \kappa_{u+1} &= \sigma_{n+u-1}^{-1}\sigma_{n+u-2}^{-1} \cdots \sigma_n^{-1} \quad \text{if } u \geq 2. \end{aligned}$$

For example if $(n, u) = (3, 2)$, then

$$\gamma = \kappa_0\kappa_1\kappa_2\kappa_3\Delta_2^2 = \sigma_2\sigma_1^2\sigma_2\sigma_3\sigma_4w_1\sigma_2\sigma_3\sigma_2^{-1}w_2\sigma_2\sigma_4^{-1}\sigma_3^{-1}\sigma_1^2. \tag{7.1}$$

If $(n, u) = (3, 3)$, then $\gamma = \kappa_0\kappa_1\kappa_2\kappa_3\kappa_4\Delta_2^2$, that is

$$\gamma = \sigma_2\sigma_1^2\sigma_2\sigma_3\sigma_4\sigma_5w_1\sigma_2\sigma_3\sigma_4\sigma_3^{-1}\sigma_2^{-1}w_2\sigma_2\sigma_3\sigma_2^{-1}w_3\sigma_2\sigma_5^{-1}\sigma_4^{-1}\sigma_3^{-1}\sigma_1^2. \tag{7.2}$$

Lemma 7.1 is used in the following situation. Suppose that $\alpha \in B_{n+u}$ is a j -increasing braid and our task is to prove that α is pseudo-Anosov and its E -surface $E_{(\alpha,j)}$ is a fiber of a fibration on $M_\alpha \rightarrow S^1$. (The conditions are needed to apply Theorem 5.2(1) for α .) To do this, we need to find an i -increasing and pseudo-Anosov braid $b \in B_n$ with $u = u(b, i)$ and need to check the resulting n -increasing braid $\gamma \in B_{n+u}$ in Lemma 7.1 satisfies the property

$$(\text{br}(\gamma), A_\gamma, \text{cl}(\gamma(n))) \sim (\text{br}(\alpha), A_\alpha, \text{cl}(\alpha(j))),$$

i.e. γ is conjugate to α preserving the corresponding strand. If this equivalence holds, then by Lemma 7.1 together with the above equivalence \sim , our task is done. As a result $\{\alpha_p\}$ has a small normalized entropy by Theorem 5.2(1).

8. Application

In the last section we prove Theorems C, D and E. We first recall a study of pseudo-Anosov 3-braids [14, 24]. Let w be a word in σ_1^{-1} and σ_2 . If both σ_1^{-1} and σ_2 occur at least once in w , then we say that w is a *pA word*. It is known that the 3-braid represented by a pA word is pseudo-Anosov. Conversely a 3-braid b is pseudo-Anosov, then there is a pA word w such that the braid represented by w is conjugate to b up to a power of the full twist.

The stable foliation \mathcal{F}_b is 1-pronged at each boundary component of F_b for each pseudo-Anosov 3-braid b . Figure 17(3) exhibits a train track automaton. A train track map for the 3-braid represented by a pA word w is obtained from the closed loop corresponding to w in the automaton. For more details, see Ham-Song [13].

8.1. Palindromic/Skew-palindromic braids.

We define a map

$$\begin{aligned} rev : B_n &\rightarrow B_n \\ \sigma_{i_1}^{\mu_1} \sigma_{i_2}^{\mu_2} \cdots \sigma_{i_k}^{\mu_k} &\mapsto \sigma_{i_k}^{\mu_k} \cdots \sigma_{i_2}^{\mu_2} \sigma_{i_1}^{\mu_1}, \quad \mu_j = \pm 1, \end{aligned}$$

which is an anti-homomorphism. A braid $b \in B_n$ is palindromic if $rev(b) = b$. Clearly $b \cdot rev(b)$ is palindromic for any $b \in B_n$. Let us consider another anti-homomorphism

$$\begin{aligned} skew : B_n &\rightarrow B_n \\ \sigma_{i_1}^{\mu_1} \sigma_{i_2}^{\mu_2} \cdots \sigma_{i_k}^{\mu_k} &\mapsto \sigma_{n-i_k}^{\mu_k} \cdots \sigma_{n-i_2}^{\mu_2} \sigma_{n-i_1}^{\mu_1}, \quad \mu_j = \pm 1. \end{aligned}$$

A braid $b \in B_n$ is skew-palindromic if $skew(b) = b$. Clearly $b \cdot skew(b)$ is skew-palindromic for any $b \in B_n$.

We now prove Theorems C and D which indicate the asymptotic behaviors of minimal entropies among these subsets are quite distinct.

Proof of Theorem C. For the surjective homomorphism $\pi : B_n \rightarrow \mathcal{S}_n$ we write $\pi_j = \pi(\sigma_j)$. Suppose that an n -braid $b = \sigma_{i_1}^{\mu_1} \sigma_{i_2}^{\mu_2} \cdots \sigma_{i_k}^{\mu_k}$ is palindromic. Since $rev(b) = b$ we have

$$(\pi_{rev(b)}) = \pi_{i_k} \cdots \pi_{i_2} \pi_{i_1} = \pi_{i_1} \pi_{i_2} \cdots \pi_{i_k} (= \pi_b).$$

Multiply the both side by $\pi_{i_1} \pi_{i_2} \cdots \pi_{i_k}$ from the left:

$$(\pi_{i_1} \pi_{i_2} \cdots \pi_{i_k}) \cdot (\pi_{i_k} \cdots \pi_{i_2} \pi_{i_1}) = (\pi_{i_1} \pi_{i_2} \cdots \pi_{i_k}) \cdot (\pi_{i_1} \pi_{i_2} \cdots \pi_{i_k}) = \pi_b^2.$$

Since $\pi_j^2 = id$ the left-hand side equals id . Hence $id = \pi_b^2$ which means that the square b^2 is pure. A theorem by Song [28] states that for a pseudo-Anosov pure element $b' \in B_n$, its dilatation has a uniform lower bound $2 + \sqrt{5} \leq \lambda(b')$. In particular if $b' = b^2$, then $2 + \sqrt{5} \leq \lambda(b^2) = (\lambda(b))^2$. This completes the proof. \square

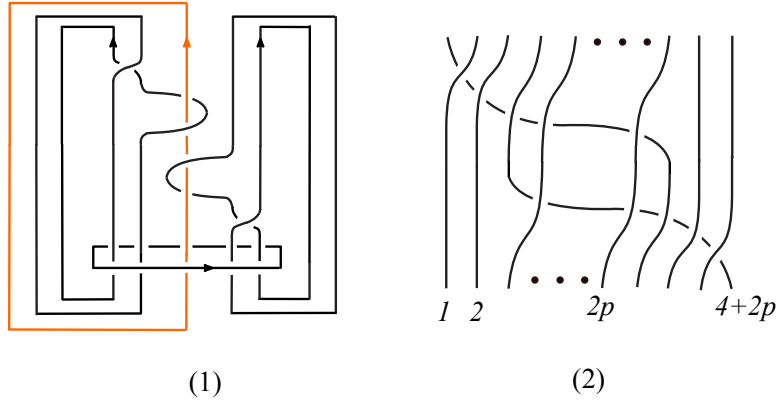

FIGURE 16. (1) $\text{br}(\xi)$. (2) Skew-palindromic $\xi_p^\bullet \in B_{4+2p}$.

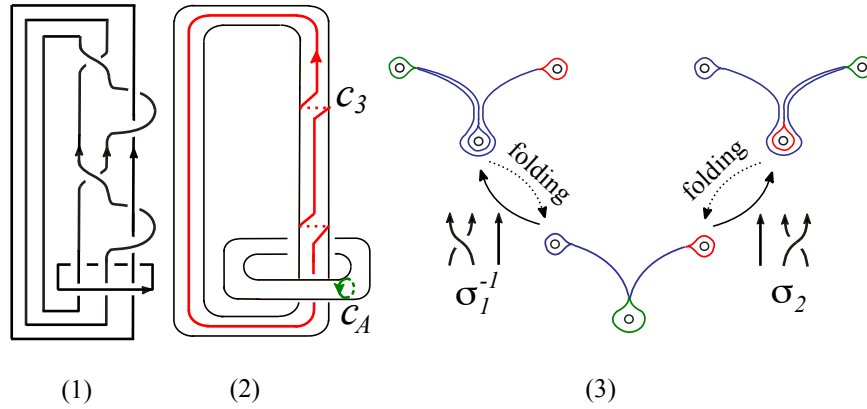

FIGURE 17. (1) $\text{br}(b)$ for $b = \sigma_1^{-1}\sigma_2^2\sigma_1^{-1}\sigma_2^2$. (2) $c_A \subset \mathcal{T}_{(b,A)}$ and $c_3 \subset \mathcal{T}_{(b,3)}$. (3) Train track automaton.

Proof of Theorem D. We separate the proof into two cases, depending on the parity of the braid degree. We first prove $\log \delta(PA_{2n}) \asymp 1/n$. Let us take $\xi = \sigma_1\sigma_2^2\sigma_3^2\sigma_4 \in B_5$ (Figure 16). The braid ξ is 3-increasing with $u(\xi, 3) = 2$. We consider the disk twist about $D_{(\xi,3)}$. We obtain the braid ξ_p which is $(3 + 2p)$ -increasing for each $p \geq 1$. Observe that ξ_p^\bullet is a skew-palindromic braid with even degree for each $p \geq 1$:

$$\xi_p^\bullet = (\sigma_1 \cdots \sigma_{1+2p})(\sigma_3 \cdots \sigma_{3+2p}) \in B_{4+2p}.$$

(For the definition of ξ_p^\bullet , see Section 5.) By the lower bound of dilatations by Penner, it is enough to prove that the sequence $\{\xi_p^\bullet\}$ has a small normalized entropy. We prove this in the following two steps. In Step 1 we prove that $\{\xi_p\}$ has a small normalized entropy. In Step 2 we prove that the stable foliation \mathcal{F}_{ξ_p} is not 1-pronged at $\partial_{(\xi_p, 3+2p)}F_{\xi_p}$ for $p \geq 1$. This tells us that ξ_p^\bullet

is pseudo-Anosov with the same dilatation as ξ_p . By Step 1 it follows that $\{\xi_p^\bullet\}$ has a small normalized entropy.

Step 1. The sequence $\{\xi_p\}$ has a small normalized entropy.

By Theorem 5.2(1) it suffices to prove that ξ is pseudo-Anosov and $[E_{(\xi,3)}]$ is a fibered class. Consider a pseudo-Anosov braid $b = \sigma_1^{-1}\sigma_2^2\sigma_1^{-1}\sigma_2^2 \in B_3$. It is 3-increasing with $u(b,3) = 2$. For $\beta = b\Delta^2$ we have $M_b \simeq M_\beta$. By Lemma 7.1 $(\text{br}(\beta), \text{cl}(\beta(3)), A_\beta) \sim (\text{br}(\gamma), A_\gamma, \text{cl}(\gamma(3)))$, where $\gamma \in B_5$ is the braid in (7.1) substituting σ_1^{-1} for w_1 and σ_1^{-1} for w_2 . It is not hard to check that¹ γ is conjugate to ξ in B_5 and their permutations have a common fixed point 3. Hence

$$(\text{br}(\beta), \text{cl}(\beta(3)), A_\beta) \sim (\text{br}(\xi), A_\xi, \text{cl}(\xi(3))). \tag{8.1}$$

In particular $E_{(\xi,3)} = F_\beta$ which means that $E_{(\xi,3)}$ is a fiber of a fibration on the hyperbolic mapping torus $M_b \simeq M_\xi$ over S^1 . Thus ξ is pseudo-Anosov.

Step 2. \mathcal{F}_{ξ_p} is $(p + 1)$ -pronged at $\partial_{(\xi_p,3+2p)}F_{\xi_p}$ for $p \geq 1$.

We read the singularity data of \mathcal{F}_{ξ_p} from the monodromy $\phi_\beta : F_\beta \rightarrow F_\beta$ of the fibration on $M_\beta \rightarrow S^1$. First consider the suspension flow ϕ_b^t on the mapping torus M_b . Since \mathcal{F}_b is 1-pronged at each component of F_b , we have simple closed curves $c_A \subset \mathcal{T}_{(b,A)}$ and $c_3 \subset \mathcal{T}_{(b,3)}$ such that $[c_A] = (1, 0)$, $[c_3] = (2, 1) \in \mathbb{Z}^2$ (Figure 17(1)(2)).

Next we turn to $\beta = b\Delta^2 \in B_3$ and the suspension flow ϕ_β^t on $M_\beta \simeq M_b$. We have simple closed curves $c_{(\beta,A)} \subset \mathcal{T}_{(\beta,A)}$ and $c_{(\beta,3)} \subset \mathcal{T}_{(\beta,3)}$. Since β is the product of b and Δ^2 , we get $[c_{(\beta,A)}] = (1, 0) + (0, 1) = (1, 1)$. The first term $(1, 0)$ comes from $[c_A]$ and the second one $(0, 1)$ comes from Δ^2 . Similarly we have $[c_{(\beta,3)}] = (2, 1) + (1, 0) = (3, 1)$. By (8.1) we have $F_\beta = E_{(\xi,3)}$ and $E_{(\beta,3)} = F_\xi$. We also have $\mathcal{T}_{(\beta,A)} = \mathcal{T}_{(\xi,3)}$ and $\mathcal{T}_{(\beta,3)} = \mathcal{T}_{(\xi,A)}$. Since

$$p[F_\beta] + [E_{(\beta,3)}] = [F_\xi] + p[E_{(\xi,3)}] = [F_\xi + pE_{(\xi,3)}] = (1, p) \in C_{(\xi,3)},$$

the stable foliation $\mathcal{F}_{(1,p)}$ associated with an integral class $(1, p) \in C_{(\xi,3)}$ is the stable foliation associated with $(p, 1) \in C_{(\beta,3)}$. By (6.1) for $(x, y) = (p, 1)$

$$[\partial_{(\beta,A)}(F_\xi + pE_{(\xi,3)})] = (-1, p), \quad [\partial_{(\beta,3)}(F_\xi + pE_{(\xi,3)})] = (-p, 1) \in \mathbb{Z}^2.$$

From $\mathbf{i}([c_{(\beta,A)}], [\partial_{(\beta,A)}(F_\xi + pE_{(\xi,3)})]) = p+1$ and $\mathbf{i}([c_{(\beta,3)}], [\partial_{(\beta,3)}(F_\xi + pE_{(\xi,3)})]) = p+3$ together with Lemma 6.1, one sees that $\mathcal{F}_{(1,p)}$ associated with $(1, p) \in C_{(\xi,3)}$ is $(p + 1)$ -pronged at $\partial_{(\beta,A)}F_{(1,p)} (= \partial_{(\xi,3)}F_{(1,p)})$, and is $(p + 3)$ -pronged at $\partial_{(\beta,3)}F_{(1,p)} (= \partial_{(\xi,A)}F_{(1,p)})$.

¹There is a solution for the conjugacy problem on B_n [6]. The software *Braiding* [12] can be used to determine whether two braids are conjugate.

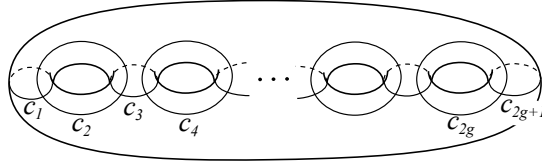

FIGURE 18. Simple closed curve C_j on Σ_g .

Since $g_p : M_\xi \rightarrow M_{\xi_p}$ sends $F_{(1,p)}$ to F_{ξ_p} the stable foliation $\mathcal{F}_{(1,p)}$ associated with $(1, p) \in C_{(\xi,3)}$ is identified with \mathcal{F}_{ξ_p} via g_p . The boundary components $\partial_{(\xi,A)}F_{(1,p)}$ and $\partial_{(\xi,3)}F_{(1,p)}$ correspond to $\partial_{(\xi_p,A)}F_{\xi_p}$ and $\partial_{(\xi_p,3+2p)}F_{\xi_p}$ respectively via g_p . Thus \mathcal{F}_{ξ_p} is $(p + 1)$ -pronged at $\partial_{(\xi_p,3+2p)}F_{\xi_p}$. This completes the proof of Step 2.

Next we prove $\log \delta(PA_{2n+1}) \asymp 1/n$ following the above arguments in Steps 1,2. Take an initial braid

$$\eta = \sigma_1\sigma_2\sigma_3\sigma_4\sigma_5\sigma_3\sigma_4\sigma_3\sigma_4\sigma_5\sigma_6\sigma_7 \in B_8.$$

It is 4-increasing with $u(\eta, 4) = 2$. Consider $\eta_p \in B_{8+2p}$ obtained from η by the disk twist. Then η_p^\bullet is a skew-palindromic braid with odd degree for each $p \geq 1$:

$$\eta_p^\bullet = (\sigma_1\sigma_2 \cdots \sigma_{4+2p})(\sigma_3\sigma_4 \cdots \sigma_{6+2p}) \in B_{7+2p}.$$

For our purpose it suffices to prove that $\{\eta_p^\bullet\}$ has a small normalized entropy. Following Step 1 we first prove that η is pseudo-Anosov and $[E_{(\eta,4)}]$ is a fibered class. Consider a pseudo-Anosov braid $b = \sigma^{-1}\sigma_2^6\Delta^2 \in B_3$ which is 3-increasing with $u(b, 3) = 5$. For $\beta = b\Delta^2$ Lemma 7.1 tells us that $(\text{br}(\beta), \text{cl}(\beta(3)), A_\beta) \sim (\text{br}(\gamma), A_\gamma, \text{cl}(\gamma(3)))$, where $\gamma = \kappa_0\kappa_1 \cdots \kappa_6\Delta_2^2 \in B_8$. One sees that γ is conjugate to η in B_8 . Since the permutation π_η has a unique fixed point it follows that $(\text{br}(\beta), \text{cl}(\beta(3)), A_\beta) \sim (\text{br}(\eta), A_\eta, \text{cl}(\eta(4)))$. This expression says that $E_{(\eta,4)} = F_\beta$ is a fiber of a fibration on the hyperbolic $M_b \simeq M_\eta$ over S^1 . Hence η is pseudo-Anosov. We conclude that $\{\eta_p^\bullet\}$ has a small normalized entropy.

Following Step 2 one sees that \mathcal{F}_{η_p} is $(p + 2)$ -pronged at $\partial_{(\eta_p,4+2p)}F_{\eta_p}$ for $p \geq 1$. Thus η_p^\bullet is pseudo-Anosov with the same dilatation as η_p . This completes the proof. \square

8.2. Spin mapping class groups. In this section we prove Theorem E. We first recall a connection between $\mathcal{H}(\Sigma_g)$ and $\text{Mod}(\Sigma_{0,2g+2})$. Let $t_j \in \text{Mod}(\Sigma_g)$ for $1 \leq j \leq 2g+1$ be the right-handed Dehn twist about the simple closed curve C_j as in Figure 18. Birman-Hilden [3] proved that $\mathcal{H}(\Sigma_g)$ is generated by $t_1, t_2, \dots, t_{2g+1}$. In fact they prove that

$$\begin{aligned} Q : \mathcal{H}(\Sigma_g) &\rightarrow \text{Mod}(\Sigma_{0,2g+2}) \\ t_j &\mapsto \mathbf{t}_j \end{aligned}$$

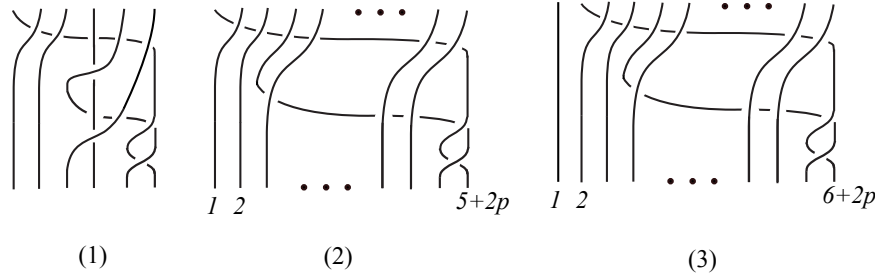

FIGURE 19. (1) $o \in B_6$. (2) $o_p^\bullet \in B_{5+2p}$. (3) $sh(o_p^\bullet) \in B_{6+2p}$.

sending t_j to the right-handed half twist \mathfrak{t}_j (see Section 2.3) is well-defined and it is a surjective homomorphism whose kernel is generated by the involution $\iota = [\mathcal{I}]$ as in Figure 5. Using the relation between $\text{Mod}(\Sigma_{0,2g+2})$ and SB_{2g+2} we have

$$\mathcal{H}(\Sigma_g)/\langle \iota \rangle \simeq \text{Mod}(\Sigma_{0,2g+2}) \simeq SB_{2g+2}/\langle \Delta^2 \rangle.$$

It is well-known that $\phi \in \mathcal{H}(\Sigma_g)$ is pseudo-Anosov if and only if $Q(\phi)$ is pseudo-Anosov and in this case $\lambda(\phi) = \lambda(Q(\phi))$ holds. The following lemma is useful to find elements of the odd/even spin mapping class groups.

Lemma 8.1 (Theorem 6.1 in [18] for (1), Theorem 3.1 in [17] for (2)). *Suppose that $g \geq 3$.*

- (1) $t_2, t_3, t_{j+1}t_j t_{j+1}^{-1}, t_k^2 \in \text{Mod}_g[\mathfrak{q}_1]$ for $4 \leq j \leq 2g$ and $1 \leq k \leq 2g + 1$.
- (2) $t_{j+1}t_j t_{j+1}^{-1}, t_k^2 \in \text{Mod}_g[\mathfrak{q}_0]$ for $1 \leq j \leq 2g$ and $1 \leq k \leq 2g + 1$.

By the above result of Birman-Hilden, all mapping classes in Lemma 8.1 are elements of $\mathcal{H}(\Sigma_g)$. Using the braid relations: $t_i t_j = t_j t_i$ if $|i - j| \geq 2$ and $t_j t_{j+1} t_j = t_{j+1} t_j t_{j+1}$ for $1 \leq j \leq 2g$, we have

$$t_j t_{j+1} t_j^{-1} = t_{j+1}^{-1} t_j t_{j+1} = t_{j+1}^{-2} (t_{j+1} t_j t_{j+1}^{-1}) t_{j+1}^2.$$

Thus Lemma 8.1 tells us that $t_j t_{j+1} t_j^{-1} \in \text{Mod}_g[\mathfrak{q}_1]$ for $4 \leq j \leq 2g$ and $t_j t_{j+1} t_j^{-1} \in \text{Mod}_g[\mathfrak{q}_0]$ for $1 \leq j \leq 2g$.

The following spin mapping classes are used in the proof of Theorem E.

Lemma 8.2. *Let $p \geq 1$ be an integer.*

- (1) $t_2 t_3 (t_4 t_5 \cdots t_{5+2p})^2 t_{5+2p} \in \text{Mod}_g[\mathfrak{q}_1]$ for any $g \geq p + 2$.
- (2) $(t_2 t_3 \cdots t_{5+2p})^2 t_{5+2p}^3 \in \text{Mod}_g[\mathfrak{q}_0]$ for any $g \geq p + 2$.

Proof. We prove the lemma by the induction on p . We first prove (1). When $p = 1$

$$t_2 t_3 (t_4 t_5 t_6 t_7)^2 t_7 = t_2 \cdot t_3 \cdot t_4 t_5 t_4^{-1} \cdot t_4^2 \cdot t_6 t_7 t_6^{-1} \cdot t_6 t_5 t_6^{-1} \cdot t_6^2 \cdot t_7^2$$

which is an element of $\text{Mod}_g[\mathfrak{q}_1]$ for $g \geq 3$ by Lemma 8.1(1).

Assume that $t_2t_3(t_4t_5 \cdots t_{5+2(p-1)})^2t_{5+2(p-1)} \in \text{Mod}_g[\mathfrak{q}_1]$ for $g \geq p - 1 + 2$. By the braid relations, $t_2t_3(t_4t_5 \cdots t_{4+2(p-1)}t_{5+2(p-1)}t_{4+2p}t_{5+2p})^2t_{5+2p}$ is equal to

$$t_2t_3(t_4t_5 \cdots t_{5+2(p-1)})^2t_{5+2(p-1)} \cdot t_{5+2(p-1)}^{-2} \cdot t_{4+2p}t_{5+2p}t_{5+2(p-1)}t_{4+2p} \cdot t_{5+2p}^2.$$

Note that $t_jt_{j+1}t_{j-1}t_j = (t_jt_{j+1}t_j^{-1})(t_jt_{j-1}t_j^{-1})t_j^2$. Then the assumption together with Lemma 8.1(1) implies that $t_2t_3(t_4t_5 \cdots t_{5+2p})^2t_{5+2p} \in \text{Mod}_g[\mathfrak{q}_1]$ for $g \geq p + 2$.

Let us turn to (2). When $p = 1$

$$(t_2t_3t_4t_5t_6t_7)^2t_7^3 = t_2t_3t_2^{-1} \cdot t_2^2 \cdot t_4t_3t_4^{-1} \cdot t_4t_5t_4^{-1} \cdot t_4^2 \cdot t_6t_7t_6^{-1} \cdot t_6t_5t_6^{-1} \cdot t_6^2 \cdot t_7^2 \cdot t_7^2$$

which is an element of $\text{Mod}_g[\mathfrak{q}_0]$ for $g \geq 3$.

Assume that $(t_2t_3 \cdots t_{5+2(p-1)})^2t_{5+2(p-1)}^3 \in \text{Mod}_g[\mathfrak{q}_0]$ for any $g \geq p - 1 + 2$. By the braid relations again, we have

$$\begin{aligned} & (t_2t_3 \cdots t_{4+2(p-1)}t_{5+2(p-1)}t_{4+2p}t_{5+2p})^2t_{5+2p}^3 \\ &= (t_2t_3 \cdots t_{5+2(p-1)})^2t_{5+2(p-1)}^3 \cdot t_{5+2(p-1)}^{-4} \cdot t_{4+2p}t_{5+2p}t_{5+2(p-1)}t_{4+2p} \cdot t_{5+2p}^4. \end{aligned}$$

The assumption together with Lemma 8.1(2) says that $(t_2t_3 \cdots t_{5+2p})^2t_{5+2p}^3 \in \text{Mod}_g[\mathfrak{q}_0]$ for $g \geq p + 2$. This completes the proof. \square

The *shift map* $sh : B_n \rightarrow B_{n+1}$ is an injective homomorphism sending σ_j to σ_{j+1} for $1 \leq j \leq n - 1$. Suppose that $b \in B_n$ is pseudo-Anosov. Then $S(sh(b)) \in SB_{n+1}$ is pseudo-Anosov with the same dilatation as b since $\widehat{\Gamma}(S(sh(b)))$ is conjugate to $f_b = \mathfrak{c}(\Gamma(b))$ in $\text{Mod}(\Sigma_{0,n+1})$. (See Section 2.3 for definitions $\Gamma, \widehat{\Gamma}$.) We finally prove Theorem E.

Proof of Theorem E(1). Consider $o = \sigma_1\sigma_2\sigma_3\sigma_4\sigma_5\sigma_3^2\sigma_4\sigma_5\sigma_3\sigma_5 \in B_6$. It is a 4-increasing braid with $u(o, 4) = 2$ (Figure 19). The braid o_p is obtained from o by disk twist for each $p \geq 1$. Then

$$\begin{aligned} o_p^\bullet &= \sigma_1\sigma_2(\sigma_3\sigma_4 \cdots \sigma_{4+2p})^2\sigma_{4+2p} \in B_{5+2p}, \\ S(sh(o_p^\bullet)) &= \sigma_2\sigma_3(\sigma_4\sigma_5 \cdots \sigma_{5+2p})^2\sigma_{5+2p} \in SB_{6+2p}. \end{aligned}$$

By Lemma 8.2(1) $t_2t_3(t_4t_5 \cdots t_{5+2p})^2t_{5+2p} \in \text{Mod}_{p+2}[\mathfrak{q}_1]$ for $p \geq 1$, and it is pseudo-Anosov if $S(sh(o_p^\bullet))$ is pseudo-Anosov. In this case they have the same dilatation. Thus by the relation between o_p^\bullet and $S(sh(o_p^\bullet))$ it is enough to prove that $\{o_p^\bullet\}$ has a small normalized entropy. We first claim that $\{o_p\}$ has a small normalized entropy. By Theorem 5.2(1) it suffices to prove that o is a pseudo-Anosov and $[E_{(o,4)}]$ is a fibered class. Consider a 3-braid $b = \sigma_1^2\sigma_2^2 \cdot \sigma_2^2 \cdot \sigma_2^2$ which is 3-increasing with $u(b, 3) = 3$. Let β denote $b\Delta^2$. By Lemma 7.1 $(\text{br}(\beta), \text{cl}(\beta(3)), A_\beta) \sim (\text{br}(\gamma), A_\gamma, \text{cl}(\gamma(3)))$, where $\gamma \in B_6$ is the braid in (7.2) substituting $\sigma_1^2, \emptyset, \emptyset$ for w_1, w_2, w_3 respectively. In this case γ is conjugate to o in B_6 . Since the permutation π_o has a unique fixed point 4, it follows that $(\text{br}(\beta), \text{cl}(\beta(3)), A_\beta) \sim (\text{br}(o), A_o, \text{cl}(o(4)))$. This tells us that $M_\beta \simeq M_o$ and $[E_{(o,4)}] = [F_\beta]$ is a fibered class. On the other hand β

is conjugate to $\sigma_1^4 \sigma_2^{-2} \Delta^4$ in B_3 which means that β is pseudo-Anosov. Thus $M_\beta \simeq M_o$ is hyperbolic and o is pseudo-Anosov.

Next we prove that o_p^\bullet is pseudo-Anosov with the same dilatation as o_p for $p \geq 1$. By the same argument as in the proof of Theorem D one sees that \mathcal{F}_{o_p} is $(p+2)$ -pronged at $\partial_{(o_p, 4+2p)} F_{o_p}$. Thus o_p^\bullet has the desired property for $p \geq 1$. We finish the proof of (1).

We turn to (2). Let us consider $v = (\sigma_1 \sigma_2 \sigma_3 \sigma_4 \sigma_5)^2 \sigma_1 \sigma_2 \sigma_5^3 \in B_6$ which is 3-increasing with $u(v, 3) = 2$. Let $v_p \in B_{6+2p}$ be the braid obtained from v by the disk twist. Then v_p is $(3+2p)$ -increasing and

$$\begin{aligned} v_p^\bullet &= (\sigma_1 \sigma_2 \cdots \sigma_{4+2p})^2 \sigma_{4+2p}^3 \in B_{5+2p}, \\ S(\text{sh}(v_p^\bullet)) &= (\sigma_2 \sigma_3 \cdots \sigma_{5+2p})^2 \sigma_{5+2p}^3 \in SB_{6+2p}. \end{aligned}$$

By Lemma 8.2(2) it is enough to prove that $\{v_p^\bullet\}$ has a small normalized entropy. To do this we first prove that $\{v_p\}$ has a small normalized entropy. Consider a pseudo-Anosov 3-braid

$$b = \sigma_1^2 \sigma_2^{-2} \Delta^4 = \sigma_1^3 \sigma_2^2 \sigma_1 \Delta^2 = \sigma_1^3 \sigma_2^2 \cdot \sigma_1^2 \sigma_2^2 \cdot \sigma_1 \sigma_2^2$$

which is 3-increasing with $u(b, 3) = 3$. Lemma 7.1 tells us that for $\beta = b\Delta^2$ we have $(\text{br}(\beta), \text{cl}(\beta(3)), A_\beta) \sim (\text{br}(\gamma), A_\gamma, \text{cl}(\gamma(3)))$, where $\gamma \in B_6$ is the braid in (7.2) substituting σ_1^3 for w_1 , σ_1^2 for w_2 and σ_1 for w_3 . One sees that γ is conjugate to v in B_6 . Thus $(\text{br}(\beta), \text{cl}(\beta(3)), A_\beta) \sim (\text{br}(v), A_v, \text{cl}(v(3)))$. This implies that $[E_{(v,3)}] = [F_\beta]$ is a fibered class of the hyperbolic $M_\beta \simeq M_v$, and hence v is pseudo-Anosov. By Theorem 5.2(1), $\{v_p\}$ has a small normalized entropy.

One sees that \mathcal{F}_{v_p} is $(p+3)$ -pronged at $\partial_{(v_p, 3+2p)} F_{v_p}$. Thus v_p^\bullet is pseudo-Anosov with the same dilatation as v_p for $p \geq 1$. This completes the proof. \square

References

- [1] ARNOUX, PIERRE; YOCCOZ, JEAN-CHRISTOPHE. Construction de difféomorphismes pseudo-Anosov. *C. R. Acad. Sci. Paris Sér. I Math.* **292** (1981), no. 1, 75–78. MR610152 (82b:57018), Zbl 0478.58023. 563
- [2] BERRICK, A. JON; GEBHARDT, VOLKER; PARIS, LUIS. Finite index subgroups of mapping class groups. *Proc. London Math. Soc.* (3) **108** (2014), no. 3, 575–599. MR3180590, Zbl 1294.57014, arXiv:1105.2468, doi:10.1112/plms/pdt022. 568
- [3] BIRMAN, JOAN S.; HILDEN, HUGH M. On the mapping class groups of closed surfaces as covering spaces. *Advances in the theory of Riemann surfaces* (Proc. Conf., Stony Brook, N.Y., 1969), 81–115. Ann. of Math. Studies, 66. Princeton Univ. Press, Princeton, N.J., 1971. MR0292082 (45#1169), Zbl 0217.48602. 592
- [4] DEHORNOY, PIERRE. Small dilatation homeomorphisms as monodromies of Lorenz knots. Preprint, 2013. *Institut Mittag-Leffler Preprints Series: IML Workshop on Growth and Mahler Measures in Geometry and Topology*, 1–9. arXiv:1402.3765. <http://www.mittag-leffler.se/sites/default/files/IML-2013summer4-01.pdf>. 564
- [5] DYE, ROGER H. On the Arf invariant. *J. Algebra* **53** (1978), no. 1, 36–39. MR485945 (5#5738), Zbl 0393.10019, doi:10.1016/0021-8693(78)90202-8. 568

- [6] EL-RIFAI, ELSAYED A.; MORTON, HUGH R. Algorithms for positive braids. *Quart. J. Math. Oxford Ser. (2)* **45** (1994), no. 180, 479–497. MR1315459 (96b:20052), Zbl 0839.20051, doi:10.1093/qmath/45.4.479. 591
- [7] FARB, BENSON; LEININGER, CHRISTOPHER J.; MARGALIT, DAN. The lower central series and pseudo-Anosov dilatations. *Amer. J. Math.* **130** (2008), no. 3, 799–827. MR2418928 (2009d:37072), Zbl 1187.37060, arXiv:math/0603675, doi:10.1353/ajm.0.0005. 567
- [8] FARB, BENSON; LEININGER, CHRISTOPHER J.; MARGALIT, DAN. Small dilatation pseudo-Anosov homeomorphisms and 3-manifolds. *Adv. Math.* **228** (2011), no. 3, 1466–1502. MR2824561 (2012f:37093), Zbl 1234.37022, arXiv:0905.0219, doi:10.1016/j.aim.2011.06.020. 563, 564
- [9] FARB, BENSON; MARGALIT, DAN. A primer on mapping class groups. Princeton Mathematical Series, 49. *Princeton University Press, Princeton, NJ*, 2012. xiv+472 pp. ISBN: 978-0-691-14794-9. MR2850125 (2012h:57032), Zbl 1245.57002, doi:10.1515/9781400839049. 563
- [10] FRIED, DAVID. Fibrations over S^1 with pseudo-Anosov monodromy. Exposé 14 in ‘Travaux de Thurston sur les surfaces’. *Astérisque* **66-67**, (1979), 251–266. MR1134426 (92g:57001), Zbl 0406.00016. 571
- [11] FRIED, DAVID. Flow equivalence, hyperbolic systems and a new zeta function for flows. *Comment. Math. Helv.* **57** (1982), no. 2, 237–259. MR684116 (84g:58083), Zbl 0503.58026. 571
- [12] GONZÁLEZ-MENESES, JUAN. Braiding: A C++ program for computations in braid groups. <http://personal.us.es/meneses/software.php>. 591
- [13] HAM, JI-YOUNG; SONG, WON TAEK. The minimum dilatation of pseudo-Anosov 5-braids. *Experiment. Math.* **16** (2007), no. 2, 167–179. MR2339273 (2008e:37043), Zbl 1151.37037, arXiv:math/0506295, doi:10.1080/10586458.2007.10129000. 589
- [14] HANDEL, MICHAEL. The forcing partial order on the three times punctured disk. *Ergodic Theory Dynam. Systems* **17** (1997), no. 3, 593–610. MR1452182 (98i:57026), Zbl 0888.58016, doi:10.1017/S0143385797084940. 589
- [15] HIRONAKA, ERIKO. Penner sequences and asymptotics of minimum dilatations for subfamilies of the mapping class group. *Topology Proc.* **44** (2014), 315–324. MR3151755, Zbl 1294.57011. 564, 567
- [16] HIRONAKA, ERIKO; KIN, EIKO. A family of pseudo-Anosov braids with small dilatation. *Algebr. Geom. Topol.* **6** (2006), 699–738. MR2240913 (2008h:57027), Zbl 1126.37014, arXiv:0904.0594, doi:10.2140/agt.2006.6.699. 563, 565, 567
- [17] HIROSE, SUSUMU. On diffeomorphisms over surfaces trivially embedded in the 4-sphere. *Algebr. Geom. Topol.* **2** (2002), 791–824. MR1928177 (2003f:57042), Zbl 1022.57016, arXiv:math/0211019, doi:10.2140/agt.2002.2.791. 593
- [18] HIROSE, SUSUMU. Surfaces in the complex projective plane and their mapping class groups. *Algebr. Geom. Topol.* **5** (2005), 577–613. MR2153115 (2006d:57037), Zbl 1092.57018, arXiv:math/0507078, doi:10.2140/agt.2005.5.577. 593
- [19] HIROSE, SUSUMU; KIN, EIKO. The asymptotic behavior of the minimal pseudo-Anosov dilatations in the hyperelliptic handlebody groups. *Q. J. Math.* **68** (2017), no. 3, 1035–1069. MR3698306, Zbl 1393.57005, arXiv:1507.01671, doi:10.1093/qmath/hax012. 567, 584
- [20] KIN, EIKO. Dynamics of the monodromies of the fibrations on the magic 3-manifold. *New York J. Math.* **21** (2015), 547–599. MR3386537, Zbl 1341.57008, arXiv:1412.7607. 564
- [21] KIN, EIKO; TAKASAWA, MITSUHIKO. Pseudo-Anosov braids with small entropy and the magic 3-manifold. *Comm. Anal. Geom.* **19** (2011), no. 4, 705–758. MR2880213, Zbl 1251.37047, arXiv:0812.4589, doi:10.4310/CAG.2011.v19.n4.a3. 564, 565

- [22] KOJIMA, SADAYOSHI; MCSHANE, GREG. Normalized entropy versus volume for pseudo-Anosovs. *Geom. Topol.* **22** (2018), no. 4, 2403–2426. MR3784525, Zbl 1398.57024, arXiv:1411.6350, doi:10.2140/gt.2018.22.2403. 563
- [23] MARGALIT, DAN. Problems, questions, and conjectures about mapping class groups. *Breadth in contemporary topology*, 157–186, Proc. Sympos. Pure Math., 102. *Amer. Math. Soc., Providence, RI*, 2019. MR3967367, arXiv:1806.08773. 566
- [24] MATSUOKA, TAKASHI. Braids of periodic points and a 2-dimensional analogue of Sharkovskii’s ordering. *Dynamical systems and nonlinear oscillations* (Kyoto, 1985), 58–72, World Sci. Adv. Ser. Dynam. Systems, 1. *World Sci. Publishing, Singapore*, 1986. MR854304 (88b:58114), Zbl 0609.58034. 589
- [25] MCMULLEN, CURTIS T. Polynomial invariants for fibered 3-manifolds and Teichmüller geodesics for foliations. *Ann. Sci. École Norm. Sup. (4)* **33** (2000), no. 4, 519–560. MR1832823 (2002d:57015), Zbl 1013.57010, doi:10.1016/S0012-9593(00)00121-X. 566
- [26] MORTON, HUGH R. Infinitely many fibred knots having the same Alexander polynomial. *Topology* **17** (1978), no. 1, 101–104. MR486796 (81e:57007), Zbl 0383.57005, doi:10.1016/0040-9383(78)90016-2. 569
- [27] PENNER, ROBERT C. Bounds on least dilatations. *Proc. Amer. Math. Soc.* **113** (1991), no. 2, 443–450. MR1068128 (91m:57010), Zbl 0726.57013, doi:10.2307/2048530. 563
- [28] SONG, WON TAEK. Upper and lower bounds for the minimal positive entropy of pure braids. *Bull. London Math. Soc.* **37** (2005), no. 2, 224–229. MR2119022 (2005k:37092), Zbl 1074.37025, doi:10.1112/S0024609304003984. 589
- [29] THURSTON, WILLIAM P. A norm for the homology of 3-manifolds. *Mem. Amer. Math. Soc.* **59** (1986), no. 339, 99–130. MR823443 (88h:57014), Zbl 0585.57006. 565, 570
- [30] THURSTON, WILLIAM P. On the geometry and dynamics of diffeomorphisms of surfaces. *Bull. Amer. Math. Soc. (N.S.)* **19** (1988), no. 2, 417–431. MR956596 (89k:57023), Zbl 0674.57008, doi:10.1090/S0273-0979-1988-15685-6. 563
- [31] THURSTON, WILLIAM P. Hyperbolic structures on 3-manifolds II: Surface groups and 3-manifolds which fiber over the circle. Preprint, 1998. arXiv:math/9801045. 563
- [32] TSAI, CHIA-YEN. The asymptotic behavior of least pseudo-Anosov dilatations. *Geom. Topol.* **13** (2009), no. 4, 2253–2278. MR2507119 (2010d:37081), Zbl 1204.37043, arXiv:0810.0261, doi:10.2140/gt.2009.13.2253. 563
- [33] VALDIVIA, AARON D. Sequences of pseudo-Anosov mapping classes and their asymptotic behavior. *New York J. Math.* **18** (2012), 609–620. MR2967106, Zbl 1350.57021, arXiv:1006.4409. 563, 564

(Susumu Hirose) DEPARTMENT OF MATHEMATICS, FACULTY OF SCIENCE AND TECHNOLOGY, TOKYO UNIVERSITY OF SCIENCE, NODA, CHIBA, 278-8510, JAPAN
hirose.susumu@ma.noda.tus.ac.jp

(Eiko Kin) DEPARTMENT OF MATHEMATICS, GRADUATE SCHOOL OF SCIENCE, OSAKA UNIVERSITY TOYONAKA, OSAKA 560-0043, JAPAN
kin@math.sci.osaka-u.ac.jp

This paper is available via <http://nyjm.albany.edu/j/2020/26-26.html>.