

DYNAMIC OBJECT MODEL

Ralph E. Johnson
Department of Computer Science
University of Illinois at Urbana-Champaign
johnson@cs.uiuc.edu

Introduction

Recently I have seen many examples of a type of architecture that was new to me. Half of the demonstrations at OOPSLA'97 were examples of this architecture. I have not found any descriptions of this architecture, yet the number of systems that I have seen indicates that it is widely used. This architecture leads to extremely extensible systems, often ones that can be extended by non-programmers. Like any architectural style, it has costs. It is not efficient of CPU time, but is usually used where efficiency isn't important. A bigger problem is that the architecture can be hard for new developers to understand. I hope this paper will help eliminate this problem.

The architecture has many names, sometimes called just a "reflective architecture" or a "meta-architecture". However, it is more specific than just a reflective architecture. It was called the "Type Instance pattern" in a tutorial at OOPSLA'95[GHV95]. This paper calls it the "Dynamic Object Model architecture". Most of the systems I have seen with a Dynamic Object Model are business systems that manage products of some sort and are extended to add new products, so I have called it the "User Defined Product architecture" in the past[JO98].

Most object-oriented systems have a static object model. In other words, the object model does not change at run-time, but is fixed when the program is designed. A system based on a Dynamic Object Model stores an object model in a database and interprets it. Changing the object model will immediately result in a changed behavior. The object model is usually easy to change because there are usually special purpose user interfaces for changing it.

The Dynamic Object Model has been used to represent insurance policies[JO98], to bill for telephone calls, and to check whether an equipment configuration is likely to work. It has been used to model workflow[DT98], to model documents, and to model databases.

The Structure of the Dynamic Object Model

The Dynamic Object Model architecture is made up of several smaller patterns. The most important is Type Object, which separates an Entity from an EntityType. Entities have Attributes, which are implemented with the Property pattern, and the Type Object pattern is used a second time to separate Attributes from AttributeTypes. The Strategy pattern is often used to define the behavior of an Entity Type. As is common in Entity-Relationship modeling, a Dynamic Object Model usually separates attributes from

relationships. Finally, there is usually an interface for non-programmers to define new EntityTypes.

Type Object

Most object-oriented languages structure a program as a set of classes. A class defines the structure and behavior of objects. Most object-oriented systems use a separate class for each kind of object, so introducing a new kind of object requires making a new class, which requires programming.

However, there is often little difference between new kinds of objects. If the difference is small enough, the objects can be generalized and the difference between them described by parameters.

For example, consider a factory scheduling system for a factory that makes many kinds of products. Each product has a different set of raw materials and requires a different set of machine tools. The factory has many kinds of machines, and has varying numbers of each. Each type of product would have a plan that indicates how to build it. The plan indicates the types of machines that are needed, but not the particular ones that are to be used. The factory scheduling system takes a set of orders and produces a schedule that ensures those orders are built on time. It assigns each order to a particular set of machines, checking that there are enough machines of a particular type to do all the work needed in a day. When the factory builds a product, it might record its BuildHistory so that quality control inspectors will know the exact machines that were used to build it.

One way to associate plans with products is to introduce a subclass of Product for each type of product, and to define an operation in each subclass to return the plan. In the same way, there would be a subclass of Machine for each type of machine. However, the only difference between MachineTypes is the number of instances and their name. Further, a plan needs to refer to machine types, and some languages (like C++) make it hard to have an object point to a class or to create an object from a class with a particular name. There should be a MachineType object that knows all the machines in the factory of a particular type. A Plan will refer to a MachineType either by name or by direct reference. A system for designing Plans might require more information about a MachineType, but a system for scheduling will not. If MachineType is a separate class then Machines are general enough that there is no reason to subclass them. In the same way, the only difference between types of products is probably the plans used to make them. It is not necessary to make a subclass of Product for each type of product; make a class ProductType and create instances of ProductType instead of subclasses of Product.

Manufacturing model

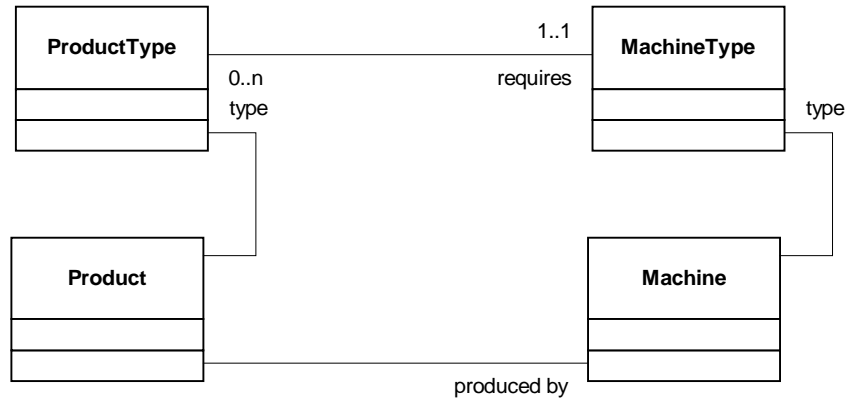

The Type Object pattern split a class into two classes, one the type of the first, and then to replace subclasses of the original with instances of the type class. It can be used in the factory scheduling system to replace subclasses of Product and Machine with instances of ProductType and MachineType. It can be used in an airline scheduling system to replace subclasses of Airplane with instances of AirplaneType (Coad 1992). It can be used in a telecommunications billing system to replace subclasses of NetworkEvent with instances of NetworkEventType. In all these cases, the difference between one type of object and another is primarily their data values, not their behavior, so the Type Object pattern works well.

Property

The attributes of an object are usually implemented by its instance variables. A class defines the instance variables of its instances. If objects of different types are all the same class, how can their attributes vary?

The solution is to implement attributes differently. Instead of each attribute being a different instance variable, make an instance variable that holds a collection of attributes.

Property Pattern

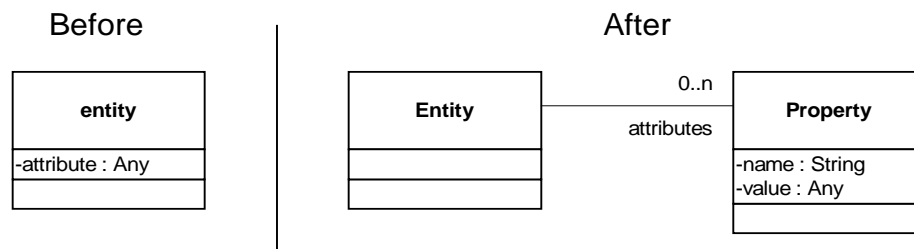

The core of a Dynamic Object Model is a combination of Type Object and Property. The Type Object pattern divides the system into Entities and EntityTypes. Entities have properties. But usually each property has a type, too, and each EntityType then specifies the types of the properties of its entities. A PropertyType is usually more like a variable declaration than like an abstract data type. It often keeps track of the name of the property, and also whether the value of the property is a number, a date, a string, etc. The result is an object model similar to the following:

Dynamic Object Model

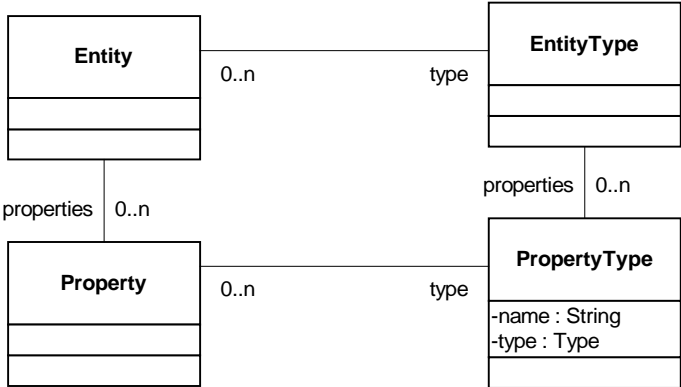

Sometimes objects differ only in having different properties. For example, a system that just reads and writes a database can use a Record with a set of Properties to represent a single record, and can use RecordType and PropertyType to represent a table.

But usually different kinds of objects have different kinds of behaviors. For example, maybe records need to be checked for consistency before being written to a database. Although many tables will have a simple consistency check, such as ensuring that numbers are within a certain range, a few will have a complex consistency checking algorithm. Thus, Property isn't enough to eliminate the need for subclasses. A Dynamic Object Model needs a way to change the behavior of objects.

Strategy

A strategy is an object that represents an algorithm. The strategy pattern defines a standard interface for a family of algorithms so that clients can work with any of them. If an object's behavior is defined by one or more strategies then that behavior is easy to change.

Each application of the strategy pattern leads to a different interface, and thus to a different class hierarchy of strategies. In a database system, strategies might be associated with each property and used to validate them. The strategies would then have one public operation, `validate()`. But strategies are more often associated with the fundamental entities being modeled, where they implement the operations on the methods.

Dynamic Object Model

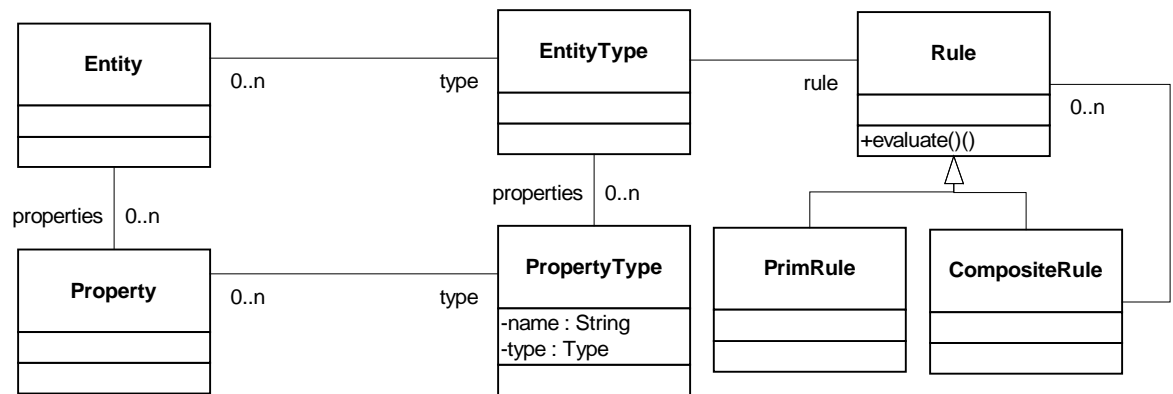

Entity-Relationship

Attributes are properties that refer to immutable values like numbers, strings, or colors. Relationships are properties that refer to other entities. Relationships are usually two-way; if Gene is the father of Carol then Carol is the daughter of Gene. This distinction, which has long been a part of classic entity-relationship modeling and which has been carried over into modern object-oriented modeling notations, is usually a part of a dynamic object-model architecture. The distinction often leads to two subclasses of properties, one for attributes and one for relationships.

One way to separate attributes from associations is to use the Property pattern twice, once for attributes and once for associations. Another way is to make two subclasses of Property, Attribute and Association. An Association would know its cardinality. A third way to separate attributes from associations is by the value of the property. Suppose there is a class Value whose subclasses are all immutable. Typical values would be numbers, strings, quantities (numbers with units), and colors. Properties whose value is an Entity are associations, while properties whose value is a Value are attributes.

Although this is a common pattern, I am not sure why it is used. Perhaps it is just a more accurate model. Or perhaps it is used by habit because designers have been trained in Entity-Relationship modeling. It is interesting that few language designers seem to feel the need to represent these relationships, but most designers of systems with dynamic object models do.

User Interface for Defining Types

One of the main reasons to design a Dynamic Object Model is to extend the system by defining new types without programming. Sometimes the goal is to enable users to extend the system without programmers. But even when only the developers will define new types, it is common to build a specialized user interface for defining types. For example, the insurance framework at the Hartford has a user interface for defining new kinds of insurance, including the rules for calculating their price. Innoverse, a telephone billing system, has a user interface for defining geographical regions, monetary units, and billing rules for different geographical regions expressed in various monetary units. The Argos school administration system lets has a user interface for defining new document types and workflows.

Types are often stored in a centralized database. This means that when someone defines new types, applications can use them without having to be recompiled. Often applications are able to use the new types immediately, while other times they cache type information and must refresh their caches before they will be able to use the new types.

The alternative to having a user interface for creating and editing type information is write programs to do it. In fact, if programmers are the only ones creating type information then it is often easier to let them do it by writing programs, since they can use their usual programming environment for this purpose. But the only way to get non-programmers to maintain the type information is give it a user interface.

Advantages of Dynamic Object Models

If a system is continually changing, or if you want users to be able to extend it, then the Dynamic Object Model architecture is often useful. The alternative is to pick a simple programming language that is flexible and easy to learn. In fact, a Dynamic Object Model is a kind of programming language. Visual Basic could be thought of as based on a Dynamic Object Model, though its internals are hidden and it is hard to be sure.

Systems based on Dynamic Object Models can be much smaller than alternatives. One architect told me that his 50,000 line system had more features than systems written without a dynamic object model that took over 3 million lines of code. I am working on replacing a system with several millions lines of code with a system based on a dynamic object model that I predict will require about 20,000 lines of code. This makes these systems easier to change by experts, and (in theory) should make them easier to understand and maintain.

Disadvantages of Dynamic Object Models

A Dynamic Object Model is hard to build. The systems that I've seen use it have all been designed by experienced architects. What happens when the system is maintained by less experienced programmers? These systems are

often hard for less experienced developers to understand. This is by far the biggest disadvantage of this architecture, and architects should choose it cautiously and plan to spend more than usual on documentation and training.

A system based on a Dynamic Object Model is an interpreter, and can be slow. Most of the systems I've seen have been fast enough with only a little optimization. However, I've also seen a few in which some of the features were too slow.

A system based on a Dynamic Object Model is defining a new language. It is a domain-specific language that is often easier for users to understand than a general-purpose language, but it is still a language. When you define a new language, you have to define support tools like a debugger, version control, and documentation tools. This is extra work. If you let users define their own types, you have to teach them good software engineering practices like testing, configuration control, and documentation. Is it worth the effort? Some designers do not worry about this and their projects usually come to a bad end. Others avoid these problems by only allowing developers to define new types. Others train their users. There are many ways around this problem, but it is a problem that should be faced and not ignored.

Summary

A Dynamic Object Model provides an interesting alternative to traditional object-oriented design. Like any architecture, it has both advantages and disadvantages. The more examples we study, the better we will understand its strengths and weaknesses. Please contact me if you have used this architecture in the past and can provide more examples or if you know of any papers that describe this architecture or aspects of it.

Bibliography

[DT98] Martine Devos and Michel Tilman, *Repository-based Framework for Evolutionary Development*, 1998. <http://www.argo.be/OoFrame/>

[FY98] Brian Foote and Joseph Yoder, *Metadata and Active Object-Models*, At PloP'98, Allerton Park, August 1998. Also <http://www-cat.ncsa.uiuc.edu/~yoder/papers/patterns/Metadata/metadata.pdf>

[GHJV95] Erich Gamma, Richard Helm, Ralph Johnson, and John Vlissides, *Design Patterns: Elements of Reusable Object-Oriented Software*, Addison-Wesley, 1995.

[GHV95] Erich Gamma, Richard Helm, and John Vlissides, *Design Patterns Applied*, tutorial notes from OOPSLA'95.

[JO98] Ralph E. Johnson and Jeff Oakes, *The User-Defined Product Framework*, 1998. <http://st.cs.uiuc.edu/pub/papers/frameworks/udp>

[JW97] Ralph Johnson and Bobbie Woolf, Type Object, In *Pattern Languages of Program Design 3*, Robert Martin, Dirk Riehle, and Frank Buschmann ed., Addison-Wesley, 1997, pp. 47-66.